

UD info Corp.

Industrial uSSD MSC-F6UB Series Product DataSheet

© 2022 UD INFO Corp. All right reserved.

Specifications are subject to change without prior notice.

UD info CORP.

3F-4, No.8, Ln. 609, Sec. 5, Chongxin Rd., Sanchong Dist., New Taipei City 241, Taiwan (R.O.C.)

TEL: +886-2-7713-6050 FAX: +886-2-8511-3151

E-mail: sales@UDinfo.com.tw

1.	Introduction	5
1.1.	General Description	5
1.2.	Block Diagram	5
2.	Product Specifications.....	6
3.	Environmental Specifications	10
3.1.	Environmental Conditions	10
3.2.	Package Qualification	11
3.3.	MTBF.....	12
3.4.	Certification & Compliance	12
4.	Electrical Specifications	13
4.1.	Supply Voltage.....	13
4.2.	Power Consumption.....	13
5.	Interface.....	15
5.1.	Pin Assignment and Descriptions	15
6.	Supported Commands.....	21
6.1.	ATA Command List.....	21
6.2.	Identify Device Data	22
7.	Physical Dimension	27
8.	Partnumber Decoder.....	30

Revision History

Revision	Draft Date	History	Author
1.0	2017/3/7	New release	Golden Lee
1.1	2017/8/4	1. Modify pin assignment 2. Update power consumption	Golden Lee
1.2	2017/9/22	1. Add pSLC support 2. Add gold temp. in part number decoder 3. Update MLC TBW	Golden Lee
1.3	2017/10/20	Remove 1.1V supply in pin description	Golden Lee
1.4	2017/11/13	Modify performance and power consumption	Golden Lee
1.5	2017/12/21	Add 3D TLC Flash support	Golden Lee
1.6	2018/2/23	Update 3D TLC TBW	Golden Lee
1.7	2018/3/29	Update performance	Golden Lee
1.8	2018/8/20	Update 3D Bics3 TBW	Golden Lee
1.9	2019/1/18	Add P/N decoder for 3D wide temperature support	Golden Lee
2.0	2021/4/27	Added Bics3 16GB support	Golden Lee
2.1	2022/7/18	Added BiCS5 support	Golden Lee

Product Overview

- **Capacity**
 - MLC: 4GB up to 128GB
 - pSLC: 2GB up to 64GB
 - BiCS3: 16GB up to 256GB
 - BiCS5: 64GB up to 512GB
- **Form Factor**
 - 16x20 mm, 156 balls, BGA SSD
- **SATA Interface**
 - SATA Revision 3.2
 - SATA 1.5Gbps, 3Gbps, and 6Gbps interface
- **Flash Interface**
 - Flash Type: MLC, BiCS3/BiCS5 TLC
- **Performance**
 - Read up to 550 MB/s
 - Write up to 495 MB/s
- **TBW (Terabyte Written)**
 - MLC: 87 TBW for 128GB
 - pSLC: 215 TBW for 64GB
 - BiCS3: 180 TBW for 256GB
 - BiCS5: 310 TBW for 512GB
- **MTBF**
 - 2,000,000 hours
- **Advanced Flash Management**
 - Static and Dynamic Wear Leveling
 - Bad Block Management
 - TRIM
 - SMART
 - Over-Provision
- **Low Power Management**
 - DIPM/HIPM Mode
- **Power Consumption^{Note1}**
 - Active mode: < 1,600 mW
 - Idle mode: < 325 mW
- **Temperature Range**
 - Operation (Standard): 0°C ~ 70°C
 - Operation (Gold): -25°C ~ 85°C
 - Operation (Wide): -40°C ~ 85°C
 - Storage: -40°C ~ 85°C
- **Compliant**
 - RoHS
 - CE & FCC

Notes:

1. Please see "Power Consumption" for details.

1. INTRODUCTION



1.1. General Description

UDinfo's MSC-F6UB delivers all the advantages of Flash Disk technology with the Serial ATA I/II/III interface in an embedded BGA form factor. Its capacity could provide a wide range from 2GB to 512GB. Moreover, it can reach up to 550MB/s read as well as 495MB/s write high performance, and lower power consumption makes it an ideal storage choice for high performance demanding mobile devices.

1.2. Block Diagram

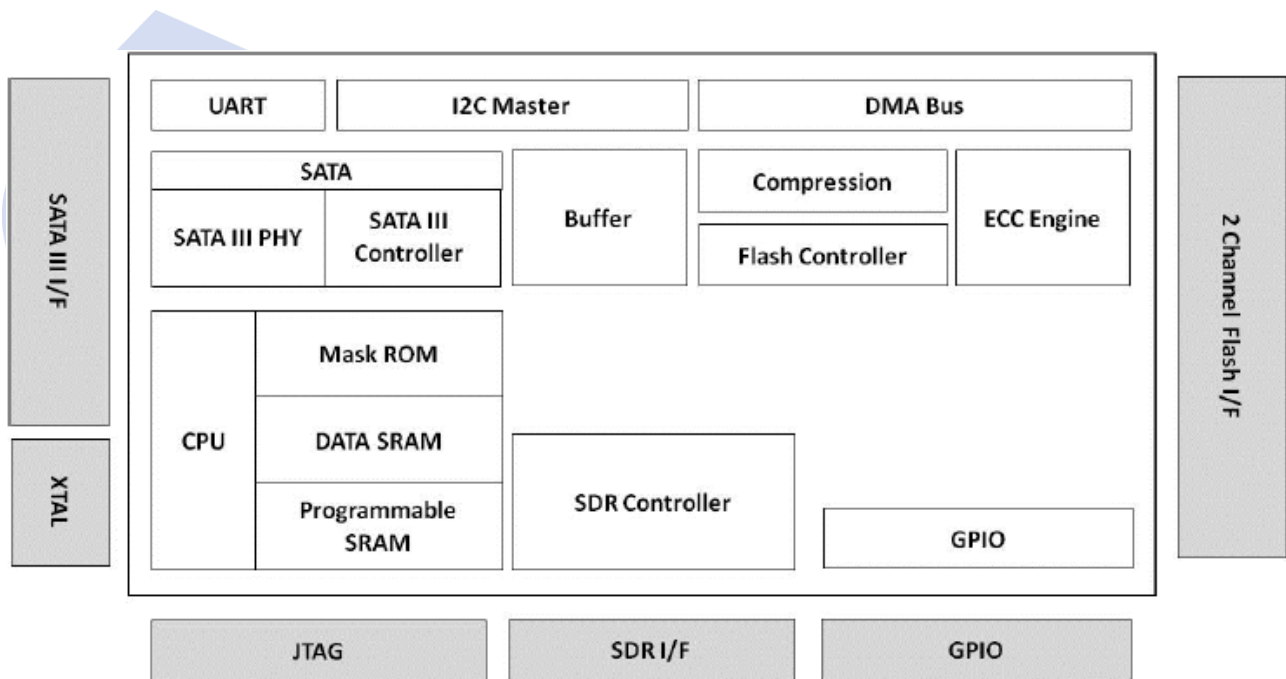

MSC-F6UB Block Diagram

2. PRODUCT SPECIFICATIONS



- **Capacity**
 - MLC: From 4GB up to 128GB (support 48-bit addressing mode)
 - pSLC: From 2GB up to 64GB (support 48-bit addressing mode)
 - BiCS3: From 16GB up to 256GB (support 48-bit addressing mode)
 - BiCS5: From 64GB up to 512GB (support 48-bit addressing mode)
- **Electrical/Physical Interface**
 - SATA Interface
 - ◆ Compliant with SATA Revision 3.0
 - ◆ Compatible with SATA 1.5Gbps, 3Gbps and 6Gbps interface
 - ◆ Support power management
 - ◆ Support expanded register for SATA protocol 48 bits addressing mode
- **NAND Flash**
 - Kioixia 15nm MLC and 3D NAND, Toggle
- **ECC Scheme**
 - Applies the LDPC (Low Density Parity Check) off ECC algorithm.
- **Operation Voltage Supply**
 - 3.3V \pm 5%
 - 1.8V \pm 5%
- **Power Saving Implementation**
 - Idle mode
 - Partial mode
 - Slumber mode
- **Built-in 32-Bit Microcontroller (Core)**
- **UART function**
- **Implement Voltage Detector**
- **GPIO**
- **Support SMART and TRIM commands**

- **Capacity Information**

Capacity	Cylinders	Heads	Sectors	Total Sectors	User Data Size
2GB	3,897	16	63	3,928,176	Depended on file management
4GB	7,773	16	63	7,835,184	
8GB	15,525	16	63	15,649,200	
16GB	16,383	16	63	31,277,232	
32GB	16,383	16	63	62,533,296	
64GB	16,383	16	63	125,045,424	
128GB	16,383	16	63	250,069,680	
256GB	16,383	16	63	500,118,192	
512GB	16,383	16	63	1,000,215,216	

- **Performance**

- **MLC:**

Capacity	Flash Structure	Flash Type	Sequential	
			Read (MB/s)	Write (MB/s)
4GB	4GB x 1	Kioxia 15nm	250	50
8GB	8GB x 1	Kioxia 15nm	300	100
16GB	8GB x 2	Kioxia 15nm	550	200
	16GB x 1		320	80
32GB	16GB x 2	Kioxia 15nm	550	155
64GB	16GB x 4	Kioxia 15nm	550	340
128GB	16GB x 8	Kioxia 15nm	550	460

- **pSLC:**

Capacity	Flash Structure	Flash Type	Sequential	
			Read (MB/s)	Write (MB/s)
2GB	4GB x 1	Kioxia 15nm	250	25
4GB	8GB x 1	Kioxia 15nm	310	100
8GB	8GB x 2	Kioxia 15nm	550	210
	16GB x 1		320	85
16GB	16GB x 2	Kioxia 15nm	280	160
32GB	16GB x 4	Kioxia 15nm	550	360
64GB	16GB x 8	Kioxia 15nm	550	460

■ BiCS3:

Capacity	Flash Structure	Flash Type	Sequential	
			Read (MB/s)	Write (MB/s)
16GB	16GB x 1	Kioixa BiCS3	275	65
32GB	32GB x 1	Kioixa BiCS3	290	70
64GB	32GB x 2	Kioixa BiCS3	540	250
128GB	32GB x 4	Kioixa BiCS3	550	450
256GB	32GB x 8	Kioixa BiCS3	550	480

■ BiCS5:

Capacity	Flash Structure	Flash Type	Sequential	
			Read (MB/s)	Write (MB/s)
64GB	64GB x 1	Kioixa BiCS5	300	170
128GB	64GB x 2	Kioixa BiCS5	540	360
256GB	64GB x 4	Kioixa BiCS5	550	465
512GB	64GB x 8	Kioixa BiCS5	550	495

Notes:

1. The performance was estimated based on Kioixa 15nm MLC / BiCS3/BiCS5 NAND flash.
2. Performance may differ according to flash configuration and platform.
3. The table above is for reference only.

- **TBW (Terabytes Written)**

- **MLC:**

Capacity	Flash Type	TBW
4GB	Kioxia 15nm	1
8GB	Kioxia 15nm	3
16GB	Kioxia 15nm	6
32GB	Kioxia 15nm	13
64GB	Kioxia 15nm	30
128GB	Kioxia 15nm	87

- **pSLC:**

Capacity	Flash Structure	TBW
2GB	Kioxia 15nm	4
4GB	Kioxia 15nm	10
8GB	Kioxia 15nm	21
16GB	Kioxia 15nm	49
32GB	Kioxia 15nm	106
64GB	Kioxia 15nm	215

- **3D TLC:**

Capacity	Flash Structure	TBW
16GB	Kioixa BiCS3	8
32GB	Kioixa BiCS3	17
64GB	Kioixa BiCS3	42
128GB	Kioixa BiCS3	75
256GB	Kioixa BiCS3	180
64GB	Kioixa BiCS5	30
128GB	Kioixa BiCS5	70
256GB	Kioixa BiCS5	150
512GB	Kioixa BiCS5	310

Notes:

1. Samples were built using Kioxia NAND flash.
2. The test followed JEDEC219A client endurance workload.
3. TBW may differ according to flash configuration and platform.
4. The endurance of SSD could be estimated based on user behavior, NAND endurance cycles, and write amplification factor. It is not guaranteed by flash vendor.

3. ENVIRONMENTAL SPECIFICATIONS

3.1. Environmental Conditions

Temperature and Humidity

- Storage Temperature range
 - -40°C to 85°C
- Operation Temperature Range
 - Commercial grade: 0°C ~ 70°C
 - Gold grade: -25°C ~ 85°C
 - Industrial grade: -40°C ~ 85°C
- Humidity: RH 95% under 55°C (in operation)

Table 3-1 High Temperature Test Condition

	Temperature	Humidity	Test Time
Operation	85°C	0% RH	72 hours
Storage	85°C	0% RH	168 hours

Result: No any abnormality is detected.

Table 3-2 Low Temperature Test Condition

	Temperature	Humidity	Test Time
Operation	-40°C	0% RH	72 hours
Storage	-40°C	0% RH	168 hours

Result: No any abnormality is detected.

Table 3-3 High Humidity Test Condition

	Temperature	Humidity	Test Time
Operation	55°C	95% RH	72 hours
Storage	55°C	95% RH	96 hours

Result: No any abnormality is detected.

Table 3-4 Temperature Cycle Test

	Temperature	Test Time	Cycle
Operation	-40°C	30 min	20 Cycles
	85°C	30 min	
Storage	-40°C	30 min	50 Cycles
	85°C	30 min	

Result: No any abnormality is detected.

UD info CORP. TEL: +886-2-7713-6050 FAX: +886-2-8511-3151

3F-4, No.8, Ln. 609, Sec. 5, Chongxin Rd., Sanchong Dist., New Taipei City 241, Taiwan (R.O.C.)

Electrostatic Discharge (ESD)

Table 3-5 Contact ESD Specification

Device	Capacity	Temperature	Relative Humidity	+/- 4KV	Result
Micro SSD	2GB	23.0°C	49% (RH)	Device functions are affected, but EUT will be back to its normal or operational state automatically.	PASS
	4GB				
	8GB				
	16GB				
	32GB				
	64GB				
	128GB				
	256GB				
	512GB				

EMI Compliance

- FCC: CISPR22
- CE: EN55022
- BSMI 13438

3.2. Package Qualification

High Temperature Storage Life Test (HTSL)

Table 3-6 HTSL Test

Parameter	Test Condition	
Storage	Temperature	Test Duration
	150°C	168/1000 hours

Result: No any abnormality is detected.

Solderability Test

Table 3-7 Solderability Test

Parameter	Test Condition
Storage	85°C/85% RH 16 hours, bake 1 hour at 125°C. Molten solder temperature: 245± 5°C Dwell time: 5 seconds

Note: Spec: > 95% of coating area, pinhole, voids, do not exceed 5% of total area.

Result: PASS

Pre-condition Test

Table 3-8 Pre-condition Test

Parameter	Test Method	Test Condition
Storage	JEDS 22-A113	1. Temperature Cycle (-65°C/150°C, 5 cycles) 2. Baking (125°C, 24 hours) 3. Temp & Humidity Soaking (30°C/60% RH, 192 hours) 4. IR Reflow 3 cycles

Note: The parts passing this test will be used to do HAST and TCT.

Results: PASS

High Acceleration Stress Test (HAST/unbias)

Table 3-9 High Acceleration Stress Test

Parameter	Test Method	Test Condition		
Storage	JEDS 22-A110	Ambient Temperature	Ambient Humidity	Test Duration
		130°C	85% RH	96 hours

Result: PASS

Temperature Cycling Test (TCT)

Table 3-10 Temperature Cycling Test

Parameter	Test Method	Test Condition		
Storage	JEDS 22-A104	High Temperature	Low Temperature	Test Duration
		150°C	-65°C	200/500 cycles

Result: PASS

3.3. MTBF

MTBF, an acronym for Mean Time Between Failures, is a measure of a device's reliability. Its value represents the average time between a repair and the next failure. The measure is typically in units of hours. The higher the MTBF value, the higher the reliability of the device. The predicted result of UDinfo's MSC-F6UB is up to 2,000,000 hours.

3.4. Certification & Compliance

- SATA III (SATA Rev. 3.0)

UD info CORP. TEL: +886-2-7713-6050 FAX: +886-2-8511-3151

3F-4, No.8, Ln. 609, Sec. 5, Chongxin Rd., Sanchong Dist., New Taipei City 241, Taiwan (R.O.C.)

- Up to ATA/ATAPI-8 (Including S.M.A.R.T)

4. ELECTRICAL SPECIFICATIONS



4.1. Supply Voltage

Table 4-1 Supply Voltage

Parameter	Rating
VCC	3.3V
VCCQ	1.8V

4.2. Power Consumption

■ MLC

Capacity	Flash Structure	Flash Type	Read	Write	Partial	Slumber	Idle
4GB	4GB x 1	Kioxia 15nm	830	820	19	14	280
8GB	8GB x 1	Kioxia 15nm	830	820	18	12	315
16GB	8GB x 2	Kioxia 15nm	1050	1000	19	13	316
	16GB x 1		850	800	15	10	265
32GB	16GB x 2	Kioxia 15nm	1050	1050	20	15	280
64GB	16GB x 4	Kioxia 15nm	1050	1500	20	12	280
128GB	16GB x 8	Kioxia 15nm	1100	1600	20	12	280

■ pSLC

Capacity	Flash Structure	Flash Type	Read	Write	Partial	Slumber	Idle
2GB	4GB x 1	Kioxia 15nm	750	720	19	14	276
4GB	8GB x 1	Kioxia 15nm	800	740	18	12	315
8GB	8GB x 2	Kioxia 15nm	950	960	19	13	316
	16GB x 1		720	660	15	10	265
16GB	16GB x 2	Kioxia 15nm	840	900	20	15	270
32GB	16GB x 4	Kioxia 15nm	900	1380	18	12	280
64GB	16GB x 8	Kioxia 15nm	910	1400	18	12	280

Unit: mW

■ **BiCS3**

Capacity	Flash Structure	Flash Type	Read	Write	Partial	Slumber	Idle
16GB	16GB x 1	Kioxia BiCS3	860	840	18	12	300
32GB	32GB x 1	Kioxia BiCS3	860	830	18	12	300
64GB	32GB x 2	Kioxia BiCS3	1130	1030	17	11	310
128GB	32GB x 4	Kioxia BiCS3	1135	1330	17	12	310
256GB	32GB x 8	Kioxia BiCS3	1215	1495	18	12	305

Unit: mW

■ **BiCS5**

Capacity	Flash Structure	Flash Type	Read	Write	Partial	Slumber	Idle
64GB	64GB x 1	Kioxia BiCS5	900	1000	18	12	315
128GB	64GB x 2	Kioxia BiCS5	1150	1300	18	12	310
256GB	64GB x 4	Kioxia BiCS5	1180	1400	18	12	315
512GB	64GB x 8	Kioxia BiCS5	1220	1430	18	12	325

Unit: mW

NOTES:

1. It's average value of power consumption based on 100% conversion efficiency.
2. Samples are made of Kioxia NAND Flash.
3. The total measured power voltage includes 1.8V, and 3.3V.
4. Sequential R/W is measures while testing 4000MB sequential R/W 5 times by CrystalDiskMark.
5. Power Consumption may vary from flash configuration and platform.

5. INTERFACE



5.1. Pin Assignment and Descriptions

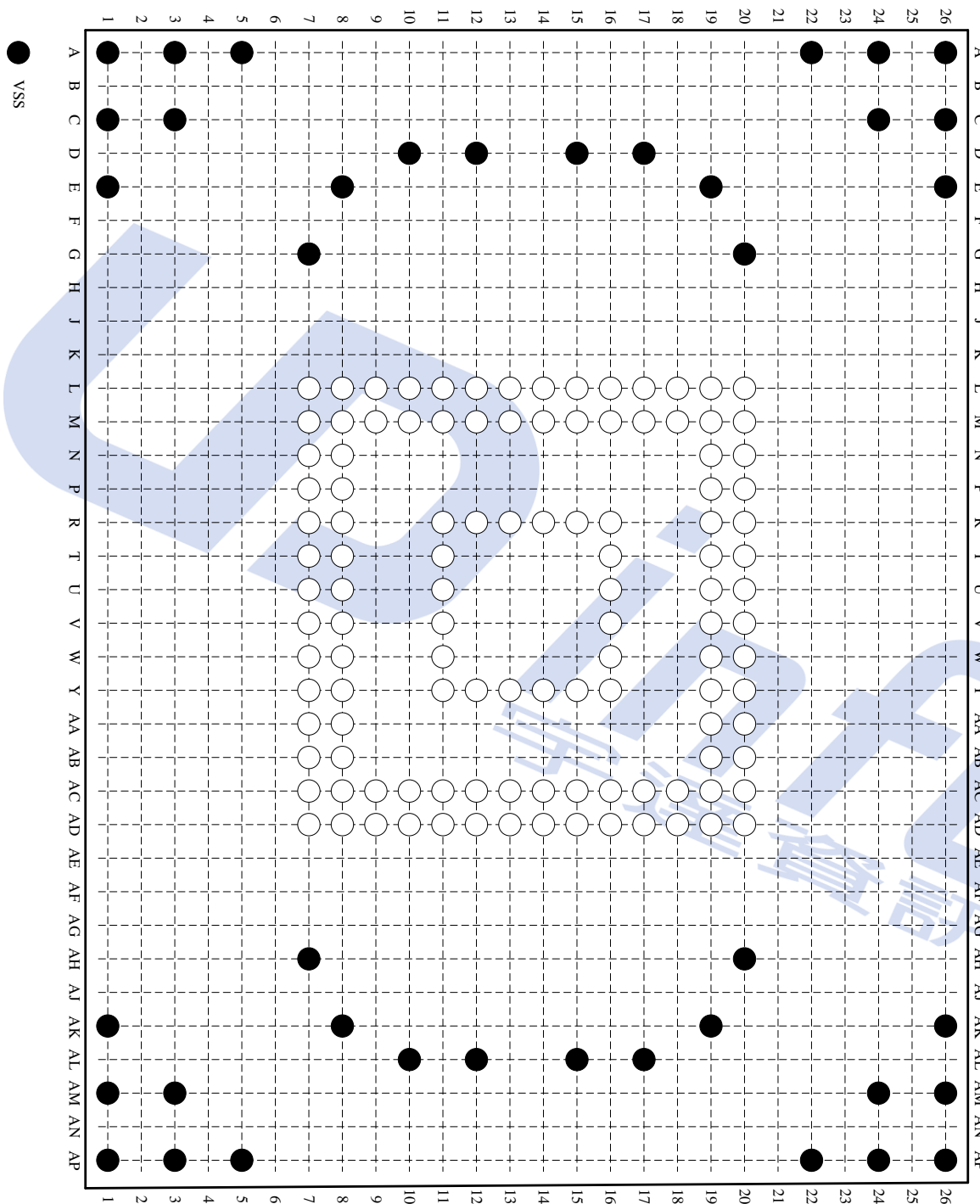

Figure 5-1 Pin Assignment (Top View)

	7	8	9	10	11	12	13	14	15	16	17	18	19	20	
L	○	○	○	○	○	○	○	○	○	○	○	○	○	○	L
	VSS	VSS	XTAL_OUT	NC	VSS	VCC	NC	NC	NC	NC	NC	NC	VSS	VSS	
M	○	○	○	○	○	○	○	○	○	○	○	○	○	○	M
	VSS	NC	PWR_RESETN	XTAL_IN	VCC	XTXD	DAS	NC	NC	NC	NC	NC	VSS	VSS	
N	○	○											○	○	N
	SATA_VSS	VSS											VSS	NC	
P	○	○											○	○	P
	SATA_RX_P	NC											VSS	VSS	
R	○	○			○	○	○	○	○	○	○		○	○	R
	SATA_RX_N	NC			NC	VSS	VCC	VCC	VCC	VCC		○	VCC	VCC	
T	○	○			○					○			○	○	T
	SATA_VSS	VSS			NC					VCC			NC	NC	
U	○	○			○					○			○	○	U
	SATA_TX_N	SATA_VCC			VSS					VCC			VSS	VSS	
V	○	○			○					○			○	○	V
	SATA_TX_P	SATA_VCC			VCC					VCCQ			VSS	NC	
W	○	○			○					○			○	○	W
	SATA_VSS	NC			VDDC					VCCQ			NC	NC	
Y	○	○			○	○	○	○	○	○			○	○	Y
	NC	NC			VDDC	VDDC	VDDC	VSS	VSS	VCCQ			VCC	VCC	
AA	○	○											○	○	AA
	NC	NC											VCC	XRTD	
AB	○	○											○	○	AB
	NC	NC											NC	NC	
AC	○	○	○	○	○	○	○	○	○	○	○	○	○	○	AC
	VSS	VCC	DEVSLP	NC	NC	NC	GPIO6	GPIO2	NC	NC	NC	NC	NC	VSS	
AD	○	○	○	○	○	○	○	○	○	○	○	○	○	○	AD
	VSS	VSS	GPIO3	NC	GPIO7	NC	GPIO13	NC	NC	NC	NC	NC	VSS	VSS	
	7	8	9	10	11	12	13	14	15	16	17	18	19	20	

Figure 5-2 Pin Assignment

Table 5-1 Pin Descriptions

Pin Name	BGA 156	Pin Type	PU/PD	Description
UART/GPIO				
XTXD	M12	O	PU 75K	UART transmit/receive port
XRXD	AA20	I		
GPIO2	AC14	IO	PU 75K	General purpose input/output pins
GPIO3	AD9			
GPIO6	AC13			
GPIO7	AD11			
GPIO13	AD13			
GPIO13	AD13			
SATA Interface signals				
SATA_RX_N	R7	I		Differential Signal Pair A. SATA Device Receive Signal Differential Pair.
SATA_RX_P	P7			
SATA_TX_N	U7	O		Differential Signal Pair B. SATA Device Transmit Signal Differential Pair.
SATA_TX_P	V7			
DAS	M13	O		Device Activity Signal
SATA_VCC	U8 V8			+3.3V
SATA_VSS	N7 T7 W7			Ground
Control Signals				
XTAL_IN	M10	I		Crystal input/output pin. (30MHz)
XTAL_OUT	L9	O		
PWR_RESETN	M9	I		Hardware Reset, low active. ^{Note1}
Power supply Signals				
VCC	L12 M11 R13 R14 R15 R16 R19 R20 T16 U16 V11 Y19 Y20 AA19 AC8			+3.3V
NC	W11 Y11 Y12 Y13			DNU
VCCQ	V16 W16 Y16			+1.8V

GND Signals				
VSS	R12 U11 L7 L8 M7 L11 L19 L20 M19 M20 N19 P19 AC20 AD20 AD19 AD8 AD7 T8 Y14 Y15 U19 P20 U20 V19 AC7 N8 A1 C1 E1 AK1 AM1			Ground
VSS	AP1 A3 C3 AM3 AP3 A5 AP5 G7 AH7 E8 AK8 D10 AL10 D12 AL12 D15 AL15 D17 AL17 E19 AK19 G20			Ground

	AH20 A22 AP22 A24 C24 AM24 AP24 A26 C26 E26 AK26 AM26 AP26			
Other Signals				
DEVSLP	AC9	I	PU 69.8K & PD 75K	DEVICE SLEEP, High active. (Normal is Low)
NC	P8 R8 L15 L16 L17 L18 AA8 AA7 AB7 AB19 AB20 AB8 AC10 AC11 AC15 AC16 AC17 AC18 AC19 AD10 AD12 AD14 AD15 AD16 AD17 AD18 L10 M16 M17 M8 T19 T20 W19 W8 Y7 Y8 L13 L14	--	--	DNU

	M14			
	M15			
	M18			
	N20			
	V20			
	W20			
	AC12			
	R11			
	T11			

Note1:

1. There is an internal Power On Reset at ball #M9 and power on sequence of internal POR is 22ms.
It's an optional function to choose whether POR (M9) is connected to an external capacitance or not.



6. SUPPORTED COMMANDS



6.1. ATA Command List

Code	Description	Code	Description
00h	NOP	97h	IDLE
06h	Data Set Management	98h	CHECK POWER MODE
10h-1Fh	Recalibrate	99h	SLEEP
20h	Read Sectors	B0h	SMART
21h	Read Sectors without Retry	B1h	DEVICE CONFIGURATION
24h	Read Sectors EXT	C4h	Read Multiple
25h	Read DMA EXT	C5h	Write Multiple
27h	Read Native Max Address EXT	C6h	Set Multiple Mode
29h	Read Multiple EXT	C8h	Read DMA
2Fh	Read Log EXT	C9h	Read DMA without Retry
30h	Write Sectors	CAh	Write DMA
31h	Write Sectors without Retry	CBh	Write DMA without Retry
34h	Write Sectors EXT	CEh	Write Multiple FUA EXT
35h	Write DMA EXT	E0h	Standby Immediate
37h	Set Native Max Address EXT	E1h	Idle Immediate
38h	CFA WRITE SECTORS WITHOUT ERASE	E2h	Standby
39h	Write Multiple EXT	E3h	Idle
3Dh	Write DMA FUA EXT	E4h	Read Buffer
3Fh	Write Long EXT	E5h	Check Power Mode
40h	Read Verify Sectors	E6h	Sleep
41h	Read Verify Sectors without Retry	E7h	Flush Cache
42h	Read Verify Sectors EXT	E8h	Write Buffer
45h	WRITE UNCORRECTABLE EXT	EAh	Flush Cache EXT
60h	Read FPDMA Queued	ECh	Identify Device
61h	Write FPDMA Queued	EFh	Set Features
70h-7Fh	Seek	F1h	Security Set Password
90h	Execute Device Diagnostic	F2h	Security Unlock
91h	Initialize Device Parameters	F3h	Security Erase Prepare
92h	Download Microcode	F4h	Security Erase Unit
93h	DOWNLOAD MICROCODE DMA	F5h	Security Freeze Lock
94h	STANDBY IMMEDIATE	F6h	Security Disable Password
95h	IDLE IMMEDIATE	F8h	Read Native Max Address
96h	STANDBY	F9h	Set Max Address

UD info CORP. TEL: +886-2-7713-6050 FAX: +886-2-8511-3151

3F-4, No.8, Ln. 609, Sec. 5, Chongxin Rd., Sanchong Dist., New Taipei City 241, Taiwan (R.O.C.)

6.2. Identify Device Data

The following table details the sector data returned by the IDENTIFY DEVICE command.

Word	F: Fixed V: Variable X: retired/obsolete /reserved	Default Value	Description
0	F	0040h	General configuration bit-significant information
1	X	*1	Obsolete – Number of logical cylinders
2	F	C837h	Specific configuration
3	X	0010h	Obsolete – Number of logical heads (16)
4-5	X	00000000h	Retired
6	X	003Fh	Obsolete – Number of logical sectors per logical track (63)
7-8	X	00000000h	Reserved for assignment by the Compact Flash Association
9	X	0000h	Retired
10-19	V	Varies	Serial number (20 ASCII characters)
20-21	X	0000h	Retired
22	X	0000h	Obsolete
23-26	V	Varies	Firmware revision (8 ASCII characters)
27-46	V	Varies	Model number (xxxxxxx)
47	F	8010h	7:0- Maximum number of sectors transferred per interrupt on MULTIPLE commands
48	F	4000h	Reserved
49	F	2F00h	Capabilities
50	F	4000h	Capabilities
51-52	X	000000000h	Obsolete
53	F	0007h	Words 88 and 70:64 valid
54	X	*1	Obsolete – Number of logical cylinders
55	X	0010h	Obsolete – Number of logical heads (16)
56	X	003Fh	Obsolete – Number of logical sectors per track (63)
57-58	X	*2	Obsolete – Current capacity in sectors
59	F	0110h	Number of sectors transferred per interrupt on MULTIPLE commands
60-61	V	*3	Maximum number of sector (28bit LBA mode)
62	X	0000h	Obsolete
63	F	0407h	Multi-word DMA modes supported/selected

UD info CORP. TEL: +886-2-7713-6050 FAX: +886-2-8511-3151

3F-4, No.8, Ln. 609, Sec. 5, Chongxin Rd., Sanchong Dist., New Taipei City 241, Taiwan (R.O.C.)

Word	F: Fixed V: Variable X: retired/obsolete /reserved	Default Value	Description
64	F	0003h	PIO modes supported
65	F	0078h	Minimum Multiword DMA transfer cycle time per word
66	F	0078h	Manufacturer's recommended Multiword DMA transfer cycle time
67	F	0078h	Minimum PIO transfer cycle time without flow control
68	F	0078h	Minimum PIO transfer cycle time with IORDY flow control
69	F	1F00h	Additional Supported
70	X	0000h	Reserved
71-74	X	000000000000 0000h	Reserved for the IDENTIFY PACKET DEVICE command
75	F	001Fh	Queue depth
76	F	850Eh	Serial SATA capabilities
77	F	0006h	Supported Serial ATA Phy speed
78	F	004Ch	Serial ATA features supported
79	F	0040H	Serial ATA features enabled
80	F	0FF8h	Major Version Number
81	F	0000h	Minor Version Number
82	F	746Bh	Command set supported
83	F	7D01h	Command set supported
84	F	4163h	Command set/feature supported extension
85	F	7469h	Command set/feature supported or enabled
86	F	BC01h	Command set/feature supported or enabled
87	F	4163h	Command set/feature supported or enabled
88	F	007Fh	Ultra DMA Modes
89	F	000Ah	Time required for Normal Erase mode SECURITY ERASE UNIT command
90	F	001Eh	Time required for an Enhanced Erase mode SECURITY ERASE UNIT command
91	F	0000h	Current advanced power management value
92	F	FFFEh	Master Password Revision Code
93	F	0000h	Hardware reset result. The contents of the bits (12:0) of this word can be changed only during the execution of hardware

Word	F: Fixed V: Variable X: retired/obsolete /reserved	Default Value	Description
			reset.
94	X	0000h	Vendor's recommended and actual acoustic management value
95	F	0000h	Stream Minimum Request Size
96	F	0000h	Streaming Transfer Time – DMA
97	F	0000h	Streaming Access Latency – DMA and PIO
98-99	F	0000h	Streaming Performance Granularity
100-103	V	*4	Maximum user LBA for 48 bit Address feature set
104	F	0000h	Streaming Transfer Time – PIO
105	F	0008h	Maximum number of 512-byte blocks per DATA SET MANAGEMENT command
106	F	4000h	Physical sector size/Logical sector size
107	F	0000h	Inter-seek delay for ISO-7779 acoustic testing in microseconds
108-111	F	Varies	Reserved
112-115	X	000000000000 0000h	Reserved
116	X	0000h	Reserved
117-118	F	00000000h	Words per logical Sector
119	F	401Ch	Supported settings
120	F	401Ch	Command set/Feature Enabled/Supported
121-126	X	0h	Reserved
127	X	0h	Obsolete
128	F	0021h	Security status
129-159	V	Varies	Vendor specific
160	X	0h	Compact Flash Association (CFA) power mode 1
161-167	X	0h	Reserved for assignment by the CFA
168	V	Varies	Device Nominal Form Factor
169	F	0001h	DATA SET MANAGEMENT command is supported
170-173	F	0h	Additional Product Identifier
174-175	X	0h	Reserve
176-205	F	0h	Current media serial number
206	F	0039h	SCT Command Transport{

Word	F: Fixed V: Variable X: retired/obsolete /reserved	Default Value	Description
207-208	X	0h	Reserved
209	F	4000h	Alignment of logical blocks within a physical block
210-211	F	0000h	Write-Read-Verify Sector Count Mode 3 (not support)
212-213	F	0000h	Write-Read-Verify Sector Count Mode 2 (not support)
214-216	X	0000h	NV Cache relate (not support)
217	F	0001h	Non-rotating media device
218	X	0h	Reserved
219	X	0h	NV Cache relate (not support)
220	V	0h	Write read verify feature set current mode
221	X	0h	Reserved
222	F	10FFh	Transport major version number
223	F	0h	Transport minor version number
224-229	X	0h	reserved
230-233	F	0h	Extend number of user addressable sectors
234	F	0001h	Minimum number of 512-byte data blocks per DOWNLOAD MICROCODE command for mode 03h
235	F	FFFEh	Maximum number of 512-byte data blocks per DOWNLOAD MICROCODE command for mode 03h
236-242	X	0h	Reserved
243	X	0000h	Reserved
244-254	X	0h	Reserved
255	F	XXA5h XX is variable	Integrity word (Checksum and Signature)

■ List of Device Identification for Each Capacity

Capacity (GB)	*1 (Word 1/Word 54)	*2 (Word 57–58)	*3 (Word 60–61)	*4 (Word 100–103)
2	F39h	3BF070h	3BF070h	3BF070h
4	1E5Dh	778E30h	778E30h	778E30h
8	3CA5h	EEC9B0h	EEC9B0h	EEC9B0h
16	3FFFh	FBFC10h	1DD40B0h	1DD40B0h
32	3FFFh	FBFC10h	3BA2EB0h	3BA2EB0h
64	3FFFh	FBFC10h	7740AB0h	7740AB0h
128	3FFFh	FBFC10h	EE7C2B0h	EE7C2B0h
256	3FFFh	FBFC10h	0FFFFFFh	1DCF32B0h
512	3FFFh	FBFC10h	0FFFFFFh	3B9E12B0h

7. PHYSICAL DIMENSION



Dimension: 16mm(L) x 20mm(W)

Top View

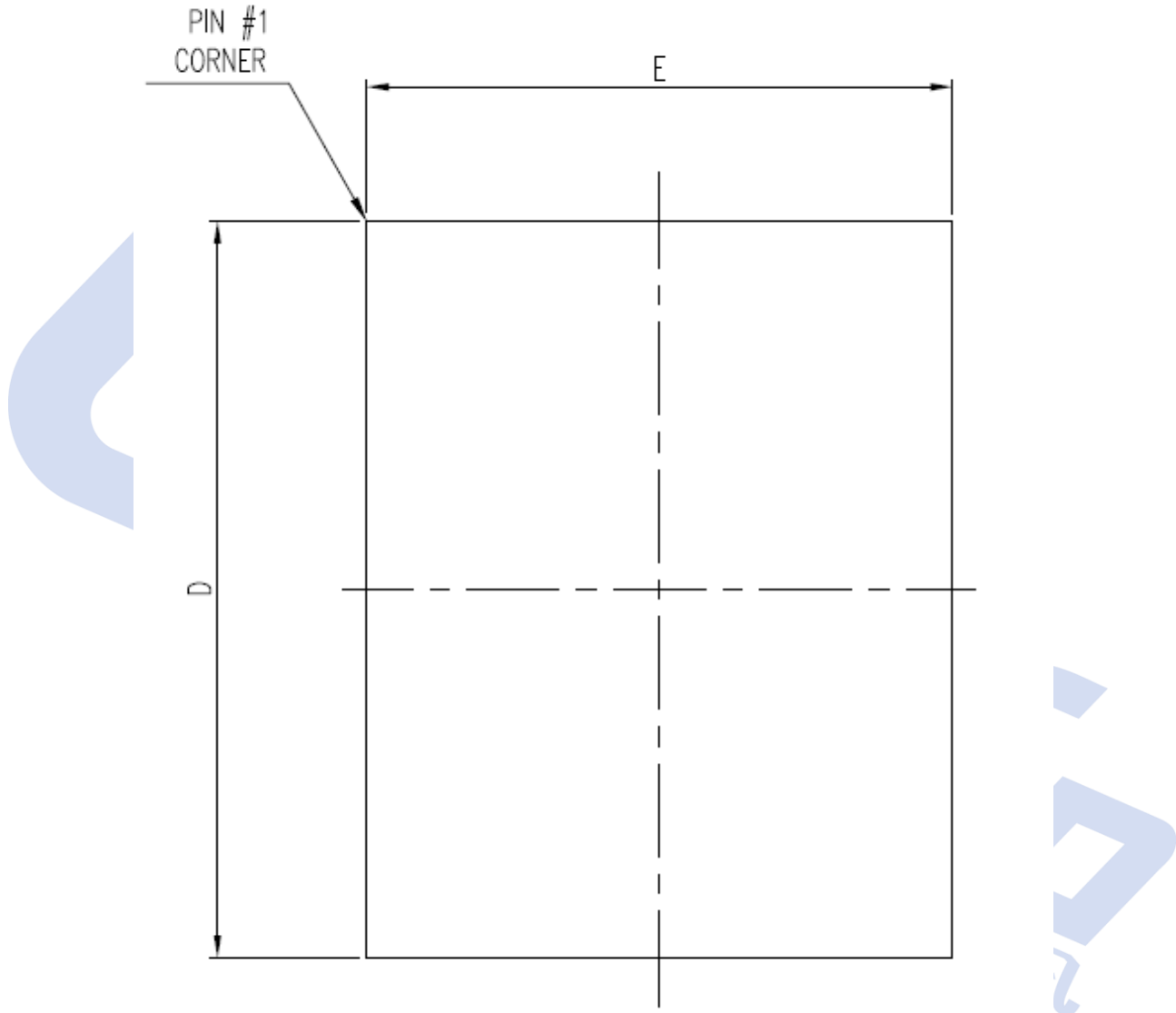

Bottom View

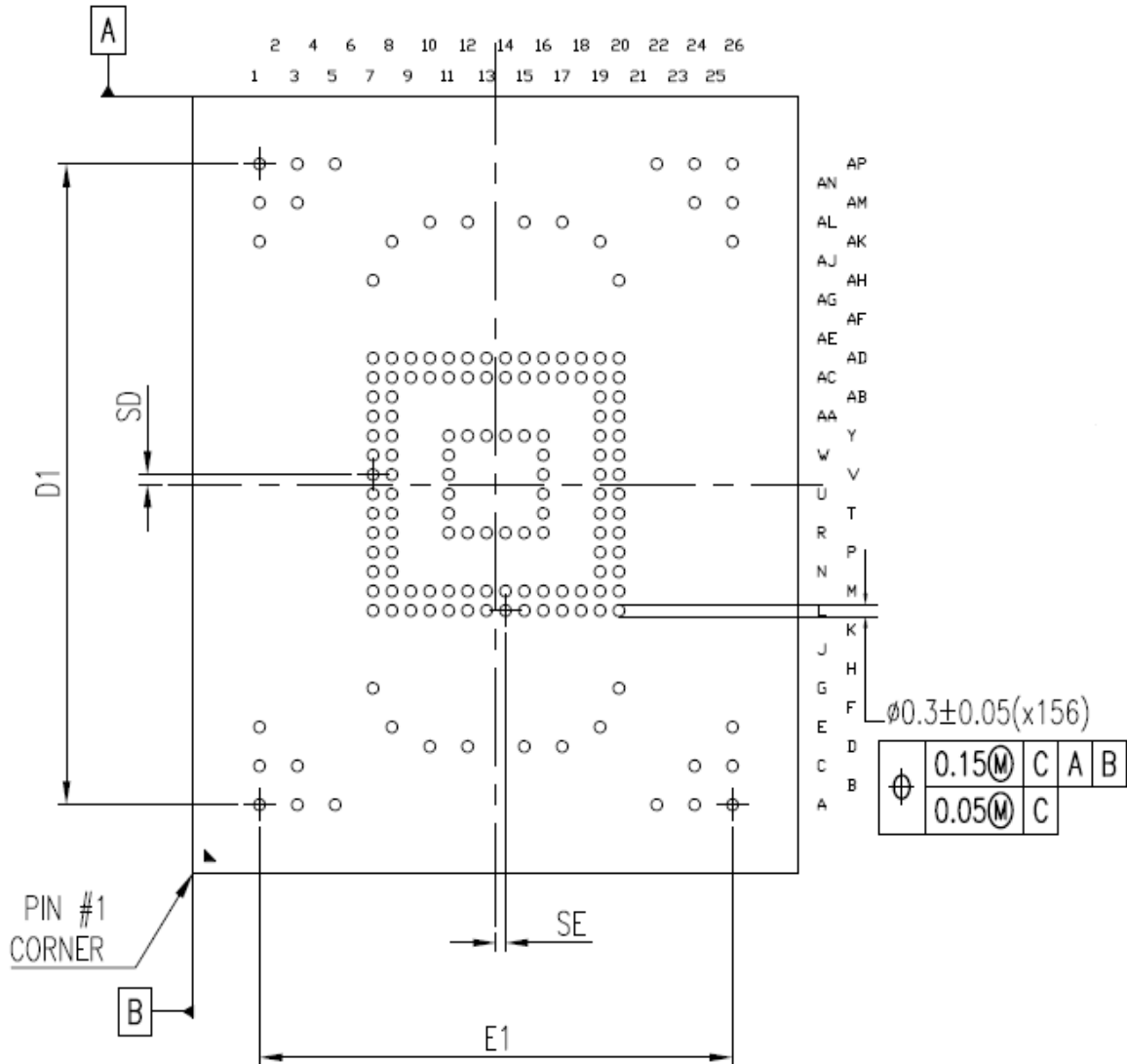

Side View

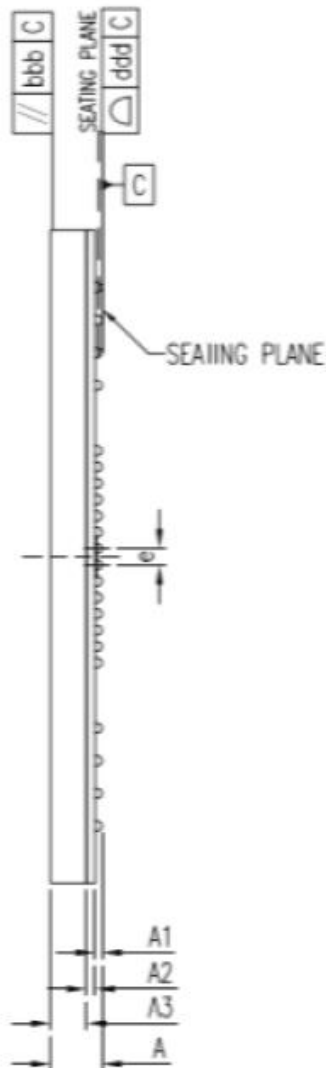

	SYMBOL	DIMENSION IN MM		
		MIN.	NOM.	MAX.
TOTAL THICKNESS	A	1.45	1.57	1.70
STAND OFF	A1	0.16	0.21	0.26
SUBSTRATE THICKNESS	A2	0.26		
MOLD THICKNESS	A3	1.10		
BODY SIZE	D	20		
	F	16		
BALL DIAMETER		0.30		
BALL OPENING		0.275		
BALL WIDTH	b	0.25	0.30	0.35
BALL PITCH	e	0.50		
BALL COUNT	n	156		
EDGE BALL CENTER TO CENTER	D1	16.50 BSC.		
	E1	12.50 BSC.		
BODY CENTER TO CONTACT BALL	SD	0.25 BSC.		
	SC	0.25 BSC.		
JEDEC(REF)		MO-276(REF.)		
PACKAGE EDGE TOLERANCE	aaa	0.15		
MOLD FLATNESS	bbb	0.20		
COPLANARITY	ddd	0.08		
BALL OFFSET(PACKAGE)	eee	0.15		
BALL OFFSET(BALL)	fff	0.05		

8. PARTNUMBER DECODER



MSC-F6UBX⁸X⁹X¹⁰X¹¹X¹²X¹³X¹⁴X¹⁵X¹⁶X¹⁷

X ¹ X ² X ³	X ⁴ X ⁵	X ⁶ X ⁷	X ⁸ X ⁹ X ¹⁰ X ¹¹ X ¹²	X ¹³	X ¹⁴	X ¹⁵	X ¹⁶ X ¹⁷
MSC	F6	UB	002GB 004GB 008GB 016GB 032GB 064GB 128GB 256GB 512GB	K: MLC Standard (0°C ~ +70°C) L: MLC Gold (-25°C ~ +85°C) M: MLC Industrial (-40°C ~ +85°C) P: pSLC Standard (0°C ~ +70°C) Q: pSLC Gold (-25°C ~ +85°C) F: pSLC Industrial (-40°C ~ +85°C) A: 3D TLC Standard (0°C ~ +70°C) B: 3D TLC Industrial (-40°C ~ +85°C)	2	P	blank

