

# UD info Corp.

## Embedded Multimedia Card (eMMC 5.1 HS400) EMC-F3UJ Series Product DataSheet

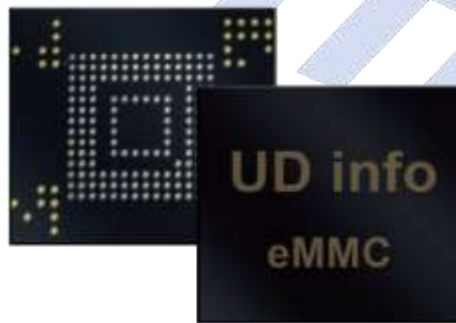

© 2023 UD INFO Corp. All right reserved.

Specifications are subject to change without prior notice.

*3F-4, No.8, Ln. 609, Sec. 5, Chongxin Rd., Sanchong Dist., New Taipei City 241, Taiwan (R.O.C.)*

*TEL: +886-2-7713-6050 FAX: +886-2-8511-3151*

*E-mail: [sales@UDinfo.com.tw](mailto:sales@UDinfo.com.tw)*

<b>1.</b>	<b>Introduction .....</b>	<b>6</b>
<b>2.</b>	<b>Power Consumption .....</b>	<b>7</b>
2.1.	Operating Voltage .....	7
2.2.	Power Consumption .....	7
<b>3.</b>	<b>Performance .....</b>	<b>11</b>
3.1.	Typical Sequential Performance .....	11
3.2.	Typical Random Performance .....	15
<b>4.</b>	<b>Operating Conditions .....</b>	<b>19</b>
4.1.	Operating and Storage Temperature .....	19
<b>5.</b>	<b>User Density .....</b>	<b>20</b>
5.1.	Capacity According to Partition .....	20
5.2.	User Density Size .....	20
<b>6.</b>	<b>eMMC Device and System .....</b>	<b>21</b>
6.1.	eMMC System Overview .....	21
6.2.	Memory Addressing .....	21
6.3.	eMMC Device Overview .....	22
6.3.1.	Clock (CLK) .....	22
6.3.2.	Data Strobe (DS) .....	22
6.3.3.	Command (CMD) .....	22
6.3.4.	Input/Outputs (DAT0-DAT7) .....	22
<b>7.</b>	<b>eMMC Functional Description .....</b>	<b>24</b>
7.1.	Pseudo Technology (pSLC) .....	24
7.2.	Field Firmware Update (FFU) .....	24
7.3.	Power off Notification for sleep .....	25
7.4.	Enhanced User Data Area .....	26
7.5.	Write Cache .....	26
7.6.	Cache Enhancement Barrier .....	27
7.7.	Cache Flushing Policy .....	28

**UD info CORP. TEL: +886-2-7713-6050 FAX: +886-2-8511-3151**

3F-4, No.8, Ln. 609, Sec. 5, Chongxin Rd., Sanchong Dist., New Taipei City 241, Taiwan (R.O.C.)

7.8.	Command Queuing (Disabled by default) .....	29
7.9.	Production State Awareness (PSA).....	29
<b>8.</b>	<b>Register Settings.....</b>	<b>31</b>
8.1.	OCR Register .....	31
8.2.	CID Register .....	31
8.3.	CSD Register.....	32
8.4.	Extended CSD Register .....	33
<b>9.</b>	<b>Package Connections .....</b>	<b>38</b>
9.1.	153 balls Package Mechanical (11.5 x 13.0 x 1.0mm) .....	38
<b>10.</b>	<b>Signal Assignment.....</b>	<b>39</b>
10.1.	153 balls .....	39
<b>11.</b>	<b>Signal Description .....</b>	<b>40</b>
<b>12.</b>	<b>Part Number Decoder.....</b>	<b>41</b>

**UD info CORP. TEL: +886-2-7713-6050 FAX: +886-2-8511-3151**

*3F-4, No.8, Ln. 609, Sec. 5, Chongxin Rd., Sanchong Dist., New Taipei City 241, Taiwan (R.O.C.)*

## Revision History

Revision	Draft Date	History	Author
1.0	2023/3/27	New Release	Golden Lee



**UD info CORP.** TEL: +886-2-7713-6050 FAX: +886-2-8511-3151

3F-4, No.8, Ln. 609, Sec. 5, Chongxin Rd., Sanchong Dist., New Taipei City 241, Taiwan (R.O.C.)

## Product Overview

- Packaged NAND flash memory with eMMC 5.1 interface
  - Compliant with eMMC Specification Ver.4.4, 4.41, 4.5, 5.0, 5.1
  - Device can be converted to eMMC 4.3, 4.41 (Shows 4.4), 4.51 (Shows 4.5), 5.0 via initializing
- Bus mode
  - High-speed eMMC protocol
  - Clock frequency: 0-200MHz.
  - Ten-wire bus (clock, 1 bit command, 8 bits data bus) and a hardware reset.
- Supports three different data bus widths: 1 bit(default), 4 bits, 8 bits
  - Data transfer rate: up to 52Mbyte/s (using 8 parallel data lines at 52 MHz)
  - Single data rate: up to 200Mbyte/s @ 200MHz
  - Dual data rate: up to 400Mbyte/s @ 200MHz
- Operating voltage range:
  - Core Voltage (V<sub>CC</sub>) = 2.7V ~ 3.6V
  - I/O Voltage (V<sub>CCQ</sub>) :
    - Automotive AEC-Q100 Grade3 & Industrial: 1.7-1.95V / 2.7-3.6V
    - Automotive AEC-Q100 Grade2: 1.7-1.95V
- Error free memory access
  - Internal error correction code (ECC) to protect data communication
  - Internal enhanced data management algorithm
  - Solid protection of sudden power failure safe-update operations for data content
- Security
  - Support secure erase/trim commands
  - Enhanced write Protection with permanent and partial protection options
- Quality
  - RoHS compliant
  - Reliability report with AEC-Q100 test items
- Major Supported Features:
  - HS400, Field Firmware Update(FFU), Power Off Notification, Pre EOL information, Enhanced Device Life time, Optimal Size
- Major Supported eMMC 5.1 Features:
  - Command Queuing, Enhanced Strobe, Cache Flushing Report, BKOPS Control, Cache Barrier, RPMB Throughput Improve, Secure Write Protection.
- Ambient Operating Temperature Range
  - Industrial: -40°C ~ 85°C
  - Automotive AEC-Q100 Grade3: -40°C ~ 85°C
  - Automotive AEC-Q100 Grade2: -40°C ~ 105°C

**UD info CORP. TEL: +886-2-7713-6050 FAX: +886-2-8511-3151**

**3F-4, No.8, Ln. 609, Sec. 5, Chongxin Rd., Sanchong Dist., New Taipei City 241, Taiwan (R.O.C.)**

# 1. Introduction

UDinfo eMMC products follow the JEDEC eMMC 5.1 standard. It is an ideal universal storage solution for many electronic devices, including smartphones, tablets, PDAs, eBook readers, digital cameras, recorders, MP3, MP4 players, electronic learning products, digital TVs and set-top boxes. eMMC encloses the 3D-64Layers NAND and eMMC controller inside as one JEDEC standard 153 balls FBGA(TFGBA) package, providing a standard interface to the host. The eMMC controller directly manages NAND flash, including ECC, wear-leveling, IOPS optimization and read sensing.

Table 1-1 Product Summary (Industrial: -40°C to +85°C Ambient)

Capacity	Flash Type	No. of Dies	V <sub>CCQ</sub>	Package Size (mm)	Weight (g)
16GB	3D - 64L, TLC	1	1.8V/3.3V	11.5 x 13 x 1.0	0.3
32GB	3D - 64L, TLC	1	1.8V/3.3V	11.5 x 13 x 1.0	0.3
64GB	3D - 64L, TLC	2	1.8V/3.3V	11.5 x 13 x 1.0	0.3
128GB	3D - 64L, TLC	4	1.8V/3.3V	11.5 x 13 x 1.0	0.3
8GB	3D - 64L, pSLC	1	1.8V/3.3V	11.5 x 13 x 1.0	0.3
16GB	3D - 64L, pSLC	2	1.8V/3.3V	11.5 x 13 x 1.0	0.3
32GB	3D - 64L, pSLC	4	1.8V/3.3V	11.5 x 13 x 1.0	0.3

Table 1-2 Product Summary (Automotive AEC-Q100 Grade3: -40°C to +85°C Ambient)

Capacity	Flash Type	No. of Dies	V <sub>CCQ</sub>	Package Size (mm)	Weight (g)
16GB	3D - 64L, TLC	1	1.8V/3.3V	11.5 x 13 x 1.0	0.3
32GB	3D - 64L, TLC	1	1.8V/3.3V	11.5 x 13 x 1.0	0.3
64GB	3D - 64L, TLC	2	1.8V/3.3V	11.5 x 13 x 1.0	0.3
128GB	3D - 64L, TLC	4	1.8V/3.3V	11.5 x 13 x 1.0	0.3
8GB	3D - 64L, pSLC	1	1.8V/3.3V	11.5 x 13 x 1.0	0.3
16GB	3D - 64L, pSLC	2	1.8V/3.3V	11.5 x 13 x 1.0	0.3
32GB	3D - 64L, pSLC	4	1.8V/3.3V	11.5 x 13 x 1.0	0.3

Table 1-3 Product Summary (Automotive AEC-Q100 Grade2: -40°C to +105°C Ambient)

Capacity	Flash Type	No. of Dies	V <sub>CCQ</sub>	Package Size (mm)	Weight (g)
16GB	3D - 64L, TLC	1	1.8V/3.3V	11.5 x 13 x 1.0	0.3
32GB	3D - 64L, TLC	1	1.8V/3.3V	11.5 x 13 x 1.0	0.3
64GB	3D - 64L, TLC	2	1.8V/3.3V	11.5 x 13 x 1.0	0.3
128GB	3D - 64L, TLC	4	1.8V/3.3V	11.5 x 13 x 1.0	0.3
8GB	3D - 64L, pSLC	1	1.8V/3.3V	11.5 x 13 x 1.0	0.3
16GB	3D - 64L, pSLC	2	1.8V/3.3V	11.5 x 13 x 1.0	0.3
32GB	3D - 64L, pSLC	4	1.8V/3.3V	11.5 x 13 x 1.0	0.3

**UD info CORP. TEL: +886-2-7713-6050 FAX: +886-2-8511-3151**

3F-4, No.8, Ln. 609, Sec. 5, Chongxin Rd., Sanchong Dist., New Taipei City 241, Taiwan (R.O.C.)

## 2. Power Consumption



### 2.1. Operating Voltage

Table 2-1 Operating Voltage

Symbol		Automotive AEC-Q100 Grade3 & Industrial		Automotive AEC-Q100 Grade2		Unit
		Min	Max	Min	Max	
V <sub>CC</sub>	3.3V	2.7	3.6	2.7	3.6	V
V <sub>CCQ</sub>	1.8V	1.7	1.95	1.7	1.95	V
	3.3V	2.7	3.6	N/A	N/A	V

### 2.2. Power Consumption

Table 2-2 TLC Device Power Consumption RMS

Speed Mode & Operation			Industrial & Automotive AEC-Q100 Grade3 (Note 3)				Automotive AEC-Q100 Grade2 (Note 4)				Unit
			16GB	32GB	64GB	128GB	16GB	32GB	64GB	128GB	
HS400	Read	I <sub>CC</sub>	100	100	110	130	50	50	50	50	mA
		I <sub>CCQ</sub>	160	160	170	170	210	210	220	230	mA
	Write	I <sub>CC</sub>	50	50	90	170	40	40	80	150	mA
		I <sub>CCQ</sub>	80	80	80	80	90	90	90	100	mA
HS200	Read	I <sub>CC</sub>	70	70	70	90	30	30	30	30	mA
		I <sub>CCQ</sub>	120	120	120	120	160	160	160	170	mA
	Write	I <sub>CC</sub>	50	50	90	170	40	40	80	150	mA
		I <sub>CCQ</sub>	80	80	80	80	90	90	90	100	mA
DDR52	Read	I <sub>CC</sub>	40	40	40	50	20	20	20	20	mA
		I <sub>CCQ</sub>	110	110	110	110	120	120	120	130	mA
	Write	I <sub>CC</sub>	50	50	90	160	40	40	80	140	mA
		I <sub>CCQ</sub>	70	70	80	80	80	80	90	100	mA
SDR52	Read	I <sub>CC</sub>	30	30	30	40	20	20	20	20	mA
		I <sub>CCQ</sub>	90	90	90	90	100	100	100	110	mA
	Write	I <sub>CC</sub>	50	50	90	140	40	40	80	130	mA
		I <sub>CCQ</sub>	70	70	80	80	80	80	90	90	mA

Notes:

**UD info CORP. TEL: +886-2-7713-6050 FAX: +886-2-8511-3151**

3F-4, No.8, Ln. 609, Sec. 5, Chongxin Rd., Sanchong Dist., New Taipei City 241, Taiwan (R.O.C.)

1. The measurement for max RMS current is done as average RMS current consumption over a period of 100ms.
2. RMS current is measured at  $T_A=25^{\circ}\text{C}$ , 8-bit bus width without clock frequency.
3. Values of Industrial & Automotive AEC-Q100 Grade3 is measured at:
  - i.  $V_{CC}=3.3\text{V}$ ,  $V_{CCQ}=1.8\text{V}$  in HS400 & HS200 mode.
  - ii.  $V_{CC}=3.3\text{V}$ ,  $V_{CCQ}=3.3\text{V}$  in DDR52MHz & SDR52MHz mode.
4. Values of Automotive AEC-Q100 Grade2 is measured at:
  - i.  $V_{CC}=3.3\text{V}$ ,  $V_{CCQ}=1.8\text{V}$  all speed modes.
5. Current numbers might be subject to changes without notice.

Table 2-3 pSLC Device Power Consumption RMS

Speed Mode & Operation			Industrial & Automotive AEC-Q100 Grade3 (Noite 3)			Automotive AEC-Q100 Grade2 (Note 4)			Unit
			8GB	16GB	32GB	8GB	16GB	32GB	
HS400	Read	$I_{CC}$	100	110	130	50	50	50	mA
		$I_{CCQ}$	160	170	170	200	210	220	mA
	Write	$I_{CC}$	50	90	170	50	80	80	mA
		$I_{CCQ}$	80	80	80	100	120	130	mA
HS200	Read	$I_{CC}$	70	70	90	30	30	30	mA
		$I_{CCQ}$	120	120	120	140	150	160	mA
	Write	$I_{CC}$	50	90	170	50	50	60	mA
		$I_{CCQ}$	80	80	80	100	110	110	mA
DDR52	Read	$I_{CC}$	40	40	50	20	20	20	mA
		$I_{CCQ}$	110	110	110	110	110	120	mA
	Write	$I_{CC}$	50	90	160	30	30	40	mA
		$I_{CCQ}$	70	80	80	90	90	90	mA
SDR52	Read	$I_{CC}$	30	30	40	20	20	20	mA
		$I_{CCQ}$	90	90	90	100	100	100	mA
	Write	$I_{CC}$	50	90	140	20	30	40	mA
		$I_{CCQ}$	70	80	80	80	80	90	mA

**Notes:**

1. The measurement for max RMS current is done as average RMS current consumption over a period of 100ms.
2. RMS current is measured at  $T_A=25^{\circ}\text{C}$ , 8-bit bus width without clock frequency.
3. Values of Industrial & Automotive AEC-Q100 Grade3 is measured at:

**UD info CORP. TEL: +886-2-7713-6050 FAX: +886-2-8511-3151**

**3F-4, No.8, Ln. 609, Sec. 5, Chongxin Rd., Sanchong Dist., New Taipei City 241, Taiwan (R.O.C.)**



- i.  $V_{CC}=3.3V, V_{CCQ}=1.8V$  in HS400 & HS200 mode.
  - ii.  $V_{CC}=3.3V, V_{CCQ}=3.3V$  in DDR52MHz & SDR52MHz mode.
4. Values of Automotive AEC-Q100 Grade2 is measured at:
- i.  $V_{CC}=3.3V, V_{CCQ}=1.8V$  all speed modes.
5. Current numbers might be subject to changes without notice.

Table 2-4 TLC Device Power Consumption Standby

Speed Mode & Operation		Industrial & Automotive AEC-Q100 Grade3 (Note 2)				Automotive AEC-Q100 Grade2 (Note 3)				Unit
		16GB	32GB	64GB	128GB	16GB	32GB	64GB	128GB	
HS400	Sleep	140	140	140	140	160	160	160	160	uA
	Standby $I_{CCQ}$	220	220	220	220	240	240	240	240	uA
	Standby $I_{CC}$	80	80	100	140	30	30	50	80	uA
HS200	Sleep	140	140	140	140	160	160	160	160	uA
	Standby $I_{CCQ}$	220	220	220	220	240	240	240	240	uA
	Standby $I_{CC}$	80	80	100	140	30	30	50	80	uA
DDR52	Sleep	180	180	180	180	160	160	160	160	uA
	Standby $I_{CCQ}$	250	250	250	250	240	240	240	240	uA
	Standby $I_{CC}$	80	80	100	140	30	30	50	80	uA
SDR52	Sleep	180	180	180	180	160	160	160	160	uA
	Standby $I_{CCQ}$	250	250	250	250	240	240	240	240	uA
	Standby $I_{CC}$	80	80	100	140	30	30	50	80	uA

**Notes:**

1. Standby current is measured at  $T_A=25^{\circ}C$ , 8-bit bus width without clock frequency.
2. Values of Industrial & Automotive AEC-Q100 Grade3 is measured at:
  - i.  $V_{CC}=3.3V, V_{CCQ}=1.8V$  in HS400 & HS200 mode.
  - ii.  $V_{CC}=3.3V, V_{CCQ}=3.3V$  in DDR52MHz & SDR52MHz mode.
3. Values of Automotive AEC-Q100 Grade2 is measured at:
  - i.  $V_{CC}=3.3V, V_{CCQ}=1.8V$  all speed modes.
4. Current numbers might be subject to changes without notice.

**UD info CORP. TEL: +886-2-7713-6050 FAX: +886-2-8511-3151**

3F-4, No.8, Ln. 609, Sec. 5, Chongxin Rd., Sanchong Dist., New Taipei City 241, Taiwan (R.O.C.)

Table 2-5 pSLC Device Power Consumption Standby

Speed Mode & Operation		Industrial & Automotive AEC-Q100 Grade3 (Note 2)			Automotive AEC-Q100 Grade2 (Note 3)			Unit
		8GB	16GB	32GB	8GB	16GB	32GB	
		HS400	Sleep	140	140	140	160	
Standby I <sub>CCQ</sub>	220		220	220	240	240	240	uA
Standby I <sub>CC</sub>	80		80	100	30	50	80	uA
HS200	Sleep	140	140	140	160	160	160	uA
	Standby I <sub>CCQ</sub>	220	220	220	240	240	240	uA
	Standby I <sub>CC</sub>	80	80	100	30	50	80	uA
DDR52	Sleep	180	180	180	160	160	160	uA
	Standby I <sub>CCQ</sub>	250	250	250	240	240	240	uA
	Standby I <sub>CC</sub>	80	80	100	30	50	80	uA
SDR52	Sleep	180	180	180	160	160	160	uA
	Standby I <sub>CCQ</sub>	250	250	250	240	240	240	uA
	Standby I <sub>CC</sub>	80	80	100	30	50	80	uA

**Notes:**

1. Standby current is measured at T<sub>A</sub>=25°C, 8-bit bus width without clock frequency.
2. Values of Industrial & Automotive AEC-Q100 Grade3 is measured at:
  - i. V<sub>CC</sub>=3.3V, V<sub>CCQ</sub>=1.8V in HS400 & HS200 mode.
  - ii. V<sub>CC</sub>=3.3V, V<sub>CCQ</sub>=3.3V in DDR52MHz & SDR52MHz mode.
3. Values of Automotive AEC-Q100 Grade2 is measured at:
  - i. V<sub>CC</sub>=3.3V, V<sub>CCQ</sub>=1.8V all speed modes.
4. Current numbers might be subject to changes without notice.

**UD info CORP. TEL: +886-2-7713-6050 FAX: +886-2-8511-3151**

3F-4, No.8, Ln. 609, Sec. 5, Chongxin Rd., Sanchong Dist., New Taipei City 241, Taiwan (R.O.C.)

### 3. Performance

#### 3.1. Typical Sequential Performance

Table 3-1 TLC Sequential Burst Performance (PSA Pseudo-SLC Burst Status)

Speed Mode & Operation			Industrial & Automotive AEC-Q100 Grade3 (Note 1)				Automotive AEC-Q100 Grade2 (Note 2)				Unit
			16GB	32GB	64GB	128GB	16GB	32GB	64GB	128GB	
HS400	Write Cache on	Read	320	320	320	320	320	320	320	320	MB/s
		Write	135	130	255	260	135	135	255	265	MB/s
	Write Cache off	Read	320	320	320	320	320	320	320	320	MB/s
		Write	130	120	205	215	130	125	205	215	MB/s
HS200	Write Cache on	Read	175	175	175	175	175	175	175	175	MB/s
		Write	135	135	150	155	130	135	155	155	MB/s
	Write Cache off	Read	175	175	175	175	175	175	175	175	MB/s
		Write	125	120	135	140	120	120	140	140	MB/s
DDR52	Write Cache on	Read	85	85	85	85	85	85	85	85	MB/s
		Write	75	75	75	75	75	75	75	75	MB/s
	Write Cache off	Read	85	85	85	85	85	85	85	85	MB/s
		Write	70	70	70	70	70	70	70	70	MB/s
SDR52	Write Cache on	Read	45	45	45	45	45	45	45	45	MB/s
		Write	40	40	40	40	40	40	40	40	MB/s
	Write Cache off	Read	45	45	45	45	45	45	45	45	MB/s
		Write	40	40	40	40	40	40	40	40	MB/s

**Notes:**

1. Performance of Industrial & Automotive AEC-Q100 Grade3 is measured at:
  - i.  $V_{CC}=3.3V, V_{CCQ}=1.8V$  in HS400 & HS200 mode.
  - ii.  $V_{CC}=3.3V, V_{CCQ}=3.3V$  in DDR52MHz & SDR52MHz mode.
2. Performance of Automotive AEC-Q100 Grade2 is measured at:
  - i.  $V_{CC}=3.3V, V_{CCQ}=1.8V$  all speed modes.
3. Performance numbers might be subject to changes without notice.
4. The write cache size is 1536KB.

**UD info CORP. TEL: +886-2-7713-6050 FAX: +886-2-8511-3151**

3F-4, No.8, Ln. 609, Sec. 5, Chongxin Rd., Sanchong Dist., New Taipei City 241, Taiwan (R.O.C.)

Table 3-2 pSLC Sequential Burst Performance

Speed Mode & Operation			Industrial & Automotive AEC-Q100 Grade3 (Note 1)			Automotive AEC-Q100 Grade2 (Note 2)			Unit
			8GB	16GB	32GB	8GB	16GB	32GB	
HS400	Write Cache on	Read	320	320	320	320	320	320	MB/s
		Write	130	255	260	135	255	265	MB/s
	Write Cache off	Read	320	320	320	320	320	320	MB/s
		Write	120	205	215	125	205	215	MB/s
HS200	Write Cache on	Read	175	175	175	175	175	175	MB/s
		Write	135	150	155	135	155	155	MB/s
	Write Cache off	Read	175	175	175	175	175	175	MB/s
		Write	120	135	140	120	140	140	MB/s
DDR52	Write Cache on	Read	85	85	85	85	85	85	MB/s
		Write	75	75	75	75	75	75	MB/s
	Write Cache off	Read	85	85	85	85	85	85	MB/s
		Write	70	70	70	70	70	70	MB/s
SDR52	Write Cache on	Read	45	45	45	45	45	45	MB/s
		Write	40	40	40	40	40	40	MB/s
	Write Cache off	Read	45	45	45	45	45	45	MB/s
		Write	40	40	40	40	40	40	MB/s

**Notes:**

1. Performance of Industrial & Automotive AEC-Q100 Grade3 is measured at:
  - i.  $V_{CC}=3.3V, V_{CCQ}=1.8V$  in HS400 & HS200 mode.
  - ii.  $V_{CC}=3.3V, V_{CCQ}=3.3V$  in DDR52MHz & SDR52MHz mode.
2. Performance of Automotive AEC-Q100 Grade2 is measured at:
  - i.  $V_{CC}=3.3V, V_{CCQ}=1.8V$  all speed modes.
3. Performance numbers might be subject to changes without notice.
4. The write cache size is 1536KB.

**UD info CORP. TEL: +886-2-7713-6050 FAX: +886-2-8511-3151**

3F-4, No.8, Ln. 609, Sec. 5, Chongxin Rd., Sanchong Dist., New Taipei City 241, Taiwan (R.O.C.)

Table 3-3 TLC Sequential Sustained Performance (Normal Status)

Speed Mode & Operation			Industrial & Automotive AEC-Q100 Grade3 (Note 1)				Automotive AEC-Q100 Grade2 (Note 2)				Unit
			16GB	32GB	64GB	128GB	16GB	32GB	64GB	128GB	
HS400	Write Cache on	Read	310	310	320	320	310	310	320	320	MB/s
		Write	15	15	35	65	15	15	30	65	MB/s
	Write Cache off	Read	310	310	320	320	315	310	320	320	MB/s
		Write	15	15	30	45	15	15	25	45	MB/s
HS200	Write Cache on	Read	175	175	175	175	175	175	175	175	MB/s
		Write	15	15	30	65	15	15	30	60	MB/s
	Write Cache off	Read	175	175	175	175	175	175	175	175	MB/s
		Write	15	15	30	45	15	15	25	45	MB/s
DDR52	Write Cache on	Read	85	85	85	85	85	85	85	85	MB/s
		Write	15	15	35	60	15	15	30	60	MB/s
	Write Cache off	Read	85	85	85	85	85	85	85	85	MB/s
		Write	15	15	25	40	15	15	25	40	MB/s
SDR52	Write Cache on	Read	45	45	45	45	45	45	45	45	MB/s
		Write	15	15	30	40	15	15	35	40	MB/s
	Write Cache off	Read	45	45	45	45	45	45	45	45	MB/s
		Write	15	15	25	30	15	15	25	30	MB/s

**Notes:**

- Performance of Industrial & Automotive AEC-Q100 Grade3 is measured at:
  - $V_{CC}=3.3V, V_{CCQ}=1.8V$  in HS400 & HS200 mode.
  - $V_{CC}=3.3V, V_{CCQ}=3.3V$  in DDR52MHz & SDR52MHz mode.
- Performance of Automotive AEC-Q100 Grade2 is measured at:
  - $V_{CC}=3.3V, V_{CCQ}=1.8V$  all speed modes.
- Performance numbers might be subject to changes without notice.
- The write cache size is 1536KB.

**UD info CORP. TEL: +886-2-7713-6050 FAX: +886-2-8511-3151**

3F-4, No.8, Ln. 609, Sec. 5, Chongxin Rd., Sanchong Dist., New Taipei City 241, Taiwan (R.O.C.)

Table 3-4 pSLC Sequential Sustained Performance (Normal Status)

Speed Mode & Operation			Industrial & Automotive AEC-Q100 Grade3 (Note 1)			Automotive AEC-Q100 Grade2 (Note 2)			Unit
			8GB	16GB	32GB	8GB	16GB	32GB	
			HS400	Write Cache on	Read	320	320	320	
Write	130	255			260	135	255	265	MB/s
Write Cache off	Read	320		320	320	320	320	320	MB/s
	Write	120		205	215	125	205	215	MB/s
HS200	Write Cache on	Read	175	175	175	175	175	175	MB/s
		Write	135	150	155	135	155	155	MB/s
	Write Cache off	Read	175	175	175	175	175	175	MB/s
		Write	120	135	140	120	140	140	MB/s
DDR52	Write Cache on	Read	85	85	85	85	85	85	MB/s
		Write	75	75	75	75	75	75	MB/s
	Write Cache off	Read	85	85	85	85	85	85	MB/s
		Write	70	70	70	70	70	70	MB/s
SDR52	Write Cache on	Read	45	45	45	45	45	45	MB/s
		Write	40	40	40	40	40	40	MB/s
	Write Cache off	Read	45	45	45	45	45	45	MB/s
		Write	40	40	40	40	40	40	MB/s

**Notes:**

- Performance of Industrial & Automotive AEC-Q100 Grade3 is measured at:
  - $V_{CC}=3.3V, V_{CCQ}=1.8V$  in HS400 & HS200 mode.
  - $V_{CC}=3.3V, V_{CCQ}=3.3V$  in DDR52MHz & SDR52MHz mode.
- Performance of Automotive AEC-Q100 Grade2 is measured at:
  - $V_{CC}=3.3V, V_{CCQ}=1.8V$  all speed modes.
- Performance numbers might be subject to changes without notice.
- The write cache size is 1536KB.

**UD info CORP. TEL: +886-2-7713-6050 FAX: +886-2-8511-3151**

3F-4, No.8, Ln. 609, Sec. 5, Chongxin Rd., Sanchong Dist., New Taipei City 241, Taiwan (R.O.C.)

### 3.2. Typical Random Performance

Table 3-5 TLC Random Burst Performance (PSA Pseudo-SLC Burst Status)

Speed Mode & Operation			Industrial & Automotive AEC-Q100 Grade3 (Note 1)				Automotive AEC-Q100 Grade2 (Note 2)				Unit
			16GB	32GB	64GB	128GB	16GB	32GB	64GB	128GB	
HS400	Write Cache on	Read	21,000	21,000	41,000	57,000	21,000	21,000	42,000	59,000	IOPS
		Write	20,000	20,000	44,000	47,000	20,000	20,000	44,000	47,000	IOPS
	Write Cache off	Read	21,000	21,000	41,000	57,000	21,000	21,000	43,000	58,000	IOPS
		Write	2,100	2,100	2,900	2,900	2,100	2,100	2,900	2,900	IOPS
HS200	Write Cache on	Read	21,000	21,000	39,000	42,000	21,000	21,000	40,000	42,000	IOPS
		Write	20,000	20,000	33,000	34,000	20,000	20,000	34,000	35,000	IOPS
	Write Cache off	Read	21,000	21,000	39,000	42,000	21,000	21,000	40,000	43,000	IOPS
		Write	2,100	2,100	2,800	2,800	2,100	2,100	2,800	2,900	IOPS
DDR52	Write Cache on	Read	19,000	19,000	21,000	21,000	19,000	19,000	21,000	21,000	IOPS
		Write	13,000	13,000	18,000	18,000	13,000	13,000	18,000	18,000	IOPS
	Write Cache off	Read	19,000	19,000	21,000	21,000	19,000	19,000	21,000	21,000	IOPS
		Write	1,900	1,900	2,600	2,600	1,900	1,900	2,700	2,600	IOPS
SDR52	Write Cache on	Read	11,000	11,000	11,000	11,000	11,000	11,000	11,000	11,000	IOPS
		Write	8,500	8,500	10,000	10,000	8,600	8,500	10,000	10,000	IOPS
	Write Cache off	Read	11,000	11,000	11,000	11,000	11,000	11,000	11,000	11,000	IOPS
		Write	1,800	1,700	2,400	2,300	1,800	1,700	2,400	2,400	IOPS

**Notes:**

1. Performance of Industrial & Automotive AEC-Q100 Grade3 is measured at:
  - i.  $V_{CC}=3.3V$ ,  $V_{CCQ}=1.8V$  in HS400 & HS200 mode.
  - ii.  $V_{CC}=3.3V$ ,  $V_{CCQ}=3.3V$  in DDR52MHz & SDR52MHz mode.
2. Performance of Automotive AEC-Q100 Grade2 is measured at:
  - i.  $V_{CC}=3.3V$ ,  $V_{CCQ}=1.8V$  all speed modes.
3. Performance numbers might be subject to changes without notice.
4. The write cache size is 1536KB.

**UD info CORP. TEL: +886-2-7713-6050 FAX: +886-2-8511-3151**

**3F-4, No.8, Ln. 609, Sec. 5, Chongxin Rd., Sanchong Dist., New Taipei City 241, Taiwan (R.O.C.)**

Table 3-6 pSLC Random Burst Performance

Speed Mode & Operation			Industrial & Automotive AEC-Q100 Grade3 (Note 1)			Automotive AEC-Q100 Grade2 (Note 2)			Unit
			8GB	16GB	32GB	8GB	16GB	32GB	
			HS400	Write Cache on	Read	21,000	41,000	57,000	
Write	20,000	44,000			47,000	20,000	44,000	47,000	IOPS
Write Cache off	Read	21,000		41,000	57,000	21,000	43,000	58,000	IOPS
	Write	2,000		2,900	2,900	2,100	2,900	2,900	IOPS
HS200	Write Cache on	Read	21,000	39,000	42,000	21,000	40,000	42,000	IOPS
		Write	20,000	33,000	34,000	20,000	34,000	35,000	IOPS
	Write Cache off	Read	21,000	39,000	42,000	21,000	40,000	43,000	IOPS
		Write	2,000	2,800	2,800	2,100	2,800	2,900	IOPS
DDR52	Write Cache on	Read	19,000	21,000	21,000	19,000	21,000	21,000	IOPS
		Write	13,000	18,000	18,000	13,000	18,000	18,000	IOPS
	Write Cache off	Read	19,000	21,000	21,000	19,000	21,000	21,000	IOPS
		Write	1,900	2,600	2,600	1,900	2,700	2,600	IOPS
SDR52	Write Cache on	Read	11,000	11,000	11,000	11,000	11,000	11,000	IOPS
		Write	8,500	10,000	10,000	8,500	10,000	10,000	IOPS
	Write Cache off	Read	11,000	11,000	11,000	11,000	11,000	11,000	IOPS
		Write	1,700	2,400	2,300	1,700	2,400	2,400	IOPS

**Notes:**

1. Performance of Industrial & Automotive AEC-Q100 Grade3 is measured at:
  - i.  $V_{CC}=3.3V, V_{CCQ}=1.8V$  in HS400 & HS200 mode.
  - ii.  $V_{CC}=3.3V, V_{CCQ}=3.3V$  in DDR52MHz & SDR52MHz mode.
2. Performance of Automotive AEC-Q100 Grade2 is measured at:
  - i.  $V_{CC}=3.3V, V_{CCQ}=1.8V$  all speed modes.
3. Performance numbers might be subject to changes without notice.
4. The write cache size is 1536KB.

**UD info CORP. TEL: +886-2-7713-6050 FAX: +886-2-8511-3151**

3F-4, No.8, Ln. 609, Sec. 5, Chongxin Rd., Sanchong Dist., New Taipei City 241, Taiwan (R.O.C.)



Table 3-7 TLC Random Sustained Performance (Normal Status)

Speed Mode & Operation			Industrial & Automotive AEC-Q100 Grade3 (Note 1)				Automotive AEC-Q100 Grade2 (Note 2)				Unit
			16GB	32GB	64GB	128GB	16GB	32GB	64GB	128GB	
HS400	Write Cache on	Read	14,000	14,000	24,000	29,000	15,000	14,000	24,000	29,000	IOPS
		Write	4,400	3,200	8,400	14,000	4,400	3,200	8,100	14,000	IOPS
	Write Cache off	Read	14,000	15,000	24,000	29,000	15,000	14,000	24,000	29,000	IOPS
		Write	1,600	1,500	1,700	1,800	1,500	1,400	1,600	1,800	IOPS
HS200	Write Cache on	Read	14,000	14,000	24,000	27,000	15,000	15,000	24,000	28,000	IOPS
		Write	4,600	3,300	8,100	14,000	4,500	3,300	7,800	13,000	IOPS
	Write Cache off	Read	15,000	15,000	24,000	27,000	14,000	14,000	24,000	43,000	IOPS
		Write	1,500	1,400	1,600	1,700	1,500	1,400	1,600	1,700	IOPS
DDR52	Write Cache on	Read	14,000	15,000	19,000	19,000	14,000	15,000	19,000	19,000	IOPS
		Write	4,300	3,100	8,000	13,000	4,600	3,200	7,900	13,000	IOPS
	Write Cache off	Read	14,000	15,000	19,000	19,000	14,000	15,000	19,000	19,000	IOPS
		Write	1,400	1,300	1,500	1,600	1,500	1,400	1,500	1,600	IOPS
SDR52	Write Cache on	Read	11,000	11,000	11,000	11,000	11,000	11,000	11,000	11,000	IOPS
		Write	4,300	3,100	8,000	9,100	4,500	3,300	8,000	9,100	IOPS
	Write Cache off	Read	11,000	11,000	11,000	11,000	11,000	11,000	11,000	11,000	IOPS
		Write	1,400	1,300	1,400	1,500	1,400	1,300	1,400	1,500	IOPS

**Notes:**

- Performance of Industrial & Automotive AEC-Q100 Grade3 is measured at:
  - $V_{CC}=3.3V, V_{CCQ}=1.8V$  in HS400 & HS200 mode.
  - $V_{CC}=3.3V, V_{CCQ}=3.3V$  in DDR52MHz & SDR52MHz mode.
- Performance of Automotive AEC-Q100 Grade2 is measured at:
  - $V_{CC}=3.3V, V_{CCQ}=1.8V$  all speed modes.
- Performance numbers might be subject to changes without notice.
- The write cache size is 1536KB.

**UD info CORP. TEL: +886-2-7713-6050 FAX: +886-2-8511-3151**

3F-4, No.8, Ln. 609, Sec. 5, Chongxin Rd., Sanchong Dist., New Taipei City 241, Taiwan (R.O.C.)

Table 3-8 pSLC Random Sustained Performance (Normal Status)

Speed Mode & Operation			Industrial & Automotive AEC-Q100 Grade3 (Note 1)			Automotive AEC-Q100 Grade2 (Note 2)			Unit
			8GB	16GB	32GB	8GB	16GB	32GB	
			HS400	Write Cache on	Read	21,000	41,000	57,000	
Write	20,000	44,000			47,000	20,000	44,000	47,000	IOPS
Write Cache off	Read	21,000		41,000	57,000	21,000	43,000	58,000	IOPS
	Write	2,000		2,900	2,900	2,100	2,900	2,900	IOPS
HS200	Write Cache on	Read	21,000	39,000	42,000	21,000	40,000	42,000	IOPS
		Write	20,000	33,000	34,000	20,000	34,000	35,000	IOPS
	Write Cache off	Read	21,000	39,000	42,000	21,000	40,000	43,000	IOPS
		Write	2,000	2,800	2,800	2,100	2,800	2,900	IOPS
DDR52	Write Cache on	Read	19,000	21,000	21,000	19,000	21,000	21,000	IOPS
		Write	13,000	18,000	18,000	13,000	18,000	18,000	IOPS
	Write Cache off	Read	19,000	21,000	21,000	19,000	21,000	21,000	IOPS
		Write	1,900	2,600	2,600	1,900	2,700	2,600	IOPS
SDR52	Write Cache on	Read	11,000	11,000	11,000	11,000	11,000	11,000	IOPS
		Write	8,500	10,000	10,000	8,500	10,000	10,000	IOPS
	Write Cache off	Read	11,000	11,000	11,000	11,000	11,000	11,000	IOPS
		Write	1,700	2,400	2,300	1,700	2,400	2,400	IOPS

**Notes:**

- Performance of Industrial & Automotive AEC-Q100 Grade3 is measured at:
  - $V_{CC}=3.3V, V_{CCQ}=1.8V$  in HS400 & HS200 mode.
  - $V_{CC}=3.3V, V_{CCQ}=3.3V$  in DDR52MHz & SDR52MHz mode.
- Performance of Automotive AEC-Q100 Grade2 is measured at:
  - $V_{CC}=3.3V, V_{CCQ}=1.8V$  all speed modes.
- Performance numbers might be subject to changes without notice.
- The write cache size is 1536KB.

**UD info CORP. TEL: +886-2-7713-6050 FAX: +886-2-8511-3151**

3F-4, No.8, Ln. 609, Sec. 5, Chongxin Rd., Sanchong Dist., New Taipei City 241, Taiwan (R.O.C.)

## 4. Operating Conditions



### 4.1. Operating and Storage Temperature

Table 4-1 Operating and Storage Temperatures: Industrial Grade

Condition	Temperature
Minimum and Maximum Ambient <sup>1</sup> Temperature	-40°C to 85°C
Maximum Case Operating Temperature	95°C
Minimum and Maximum Non-operating Temperature <sup>2</sup>	-40°C to 85°C

Table 4-2 Operating and Storage Temperatures: Automotive AEC-Q100 Grade3

Condition	Temperature
Minimum and Maximum Ambient <sup>1</sup> Temperature	-40°C to 85°C
Maximum Case Operating Temperature	95°C
Minimum and Maximum Non-operating Temperature <sup>2</sup>	-40°C to 85°C

Table 4-3 Operating and Storage Temperatures: Automotive AEC-Q100 Grade2

Condition	Temperature
Minimum and Maximum Ambient <sup>1</sup> Temperature	-40°C to 105°C
Maximum Case Operating Temperature	115°C
Minimum and Maximum Non-operating Temperature <sup>2</sup>	-40°C to 105°C

**Notes:**

1. To achieve optimized power and performance, case temperature should not exceed maximum ambient operating temperature.
2. After being soldered onto PCBA.

**UD info CORP.** TEL: +886-2-7713-6050 FAX: +886-2-8511-3151

3F-4, No.8, Ln. 609, Sec. 5, Chongxin Rd., Sanchong Dist., New Taipei City 241, Taiwan (R.O.C.)

## 5. User Density



### 5.1. Capacity According to Partition

Table 5-1 Capacity According to Partition

Capacity	Boot Partition 1	Boot Partition 2	RPMB
8GB	4096 KB	4096 KB	4096 KB
16GB	4096 KB	4096 KB	4096 KB
32GB	4096 KB	4096 KB	4096 KB
64GB	4096 KB	4096 KB	4096 KB
128GB	4096 KB	4096 KB	4096 KB

### 5.2. User Density Size

Total user density depends on device type.

Table 5-2 User Density Size

Grade	Flash Mode	Device	User Density
Industrial	pSLC	8GB	7,817,134,080 Bytes
	TLC / pSLC	16GB	15,634,268,160 Bytes
	TLC / PSLC	32GB	31,268,536,320 Bytes
	TLC	64GB	62,537,072,640 Bytes
	TLC	128GB	125,074,145,280 Bytes
Automotive AEC-Q100 Grade3	pSLC	8GB	7,817,134,080 Bytes
	TLC / pSLC	16GB	15,634,268,160 Bytes
	TLC / PSLC	32GB	31,268,536,320 Bytes
	TLC	64GB	62,537,072,640 Bytes
	TLC	128GB	125,074,145,280 Bytes
Automotive AEC-Q100 Grade2	pSLC	8GB	15,634,268,160 Bytes
	TLC / pSLC	16GB	7,817,134,080 Bytes
	TLC / PSLC	32GB	31,268,536,320 Bytes
	TLC	64GB	62,537,072,640 Bytes
	TLC	128GB	125,074,145,280 Bytes

UD info CORP. TEL: +886-2-7713-6050 FAX: +886-2-8511-3151

3F-4, No.8, Ln. 609, Sec. 5, Chongxin Rd., Sanchong Dist., New Taipei City 241, Taiwan (R.O.C.)

## 6. eMMC Device and System

### 6.1. eMMC System Overview

The eMMC specification covers the behavior of the interface and the Device controller. As part of this specification the existence of a host controller and a memory storage array are implied but the operation of these pieces is not fully specified.

UDinfo NAND Device consists of a single chip MMC controller and NAND flash memory module. The micro- controller interfaces with a host system allowing data to be written to and read from the NAND flash memory module. The controller allows the host to be independent from details of erasing and programming the flash memory.

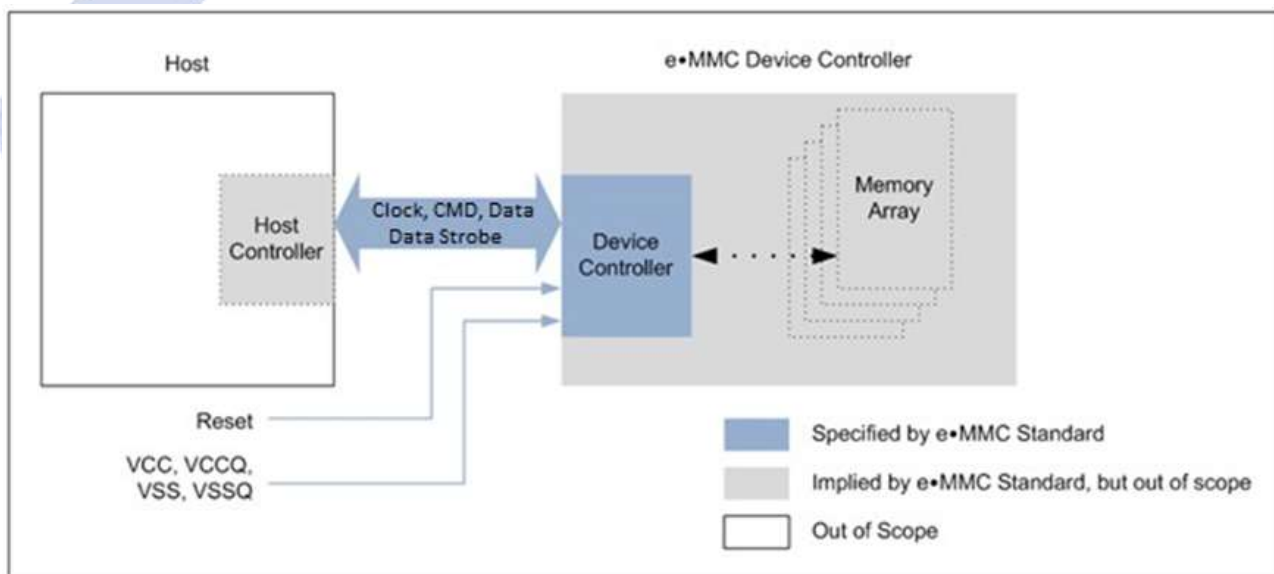

Figure 1 – eMMC System Overview

### 6.2. Memory Addressing

Previous implementations of the eMMC specification are following byte addressing with 32 bit field. This addressing mechanism permitted for eMMC densities up to and including 2 GB. To support larger densities the addressing mechanism was update to support sector addresses (512 B sectors). The sector addresses shall be used for all devices with capacity larger than 2 GB. To determine the addressing mode, use the host should read bit [30:29] in the OCR register.

**UD info CORP. TEL: +886-2-7713-6050 FAX: +886-2-8511-3151**

3F-4, No.8, Ln. 609, Sec. 5, Chongxin Rd., Sanchong Dist., New Taipei City 241, Taiwan (R.O.C.)

### 6.3. eMMC Device Overview

The *eMMC* device transfers data via a configurable number of data bus signals. The communication signals are:

#### 6.3.1. Clock (CLK)

Each cycle of this signal directs a one-bit transfer on the command and either a one bit (1x) or a two bits transfer (2x) on all the data lines. The frequency may vary between zero and the maximum clock frequency.

#### 6.3.2. Data Strobe (DS)

This signal is generated by the device and used for output in HS400 mode. The frequency of this signal follows the frequency of CLK. For data output each cycle of this signal directs two bits transfer(2x) on the data - one bit for positive edge and the other bit for negative edge. For CRC status response output and CMD response output (enabled only HS400 enhanced strobe mode), the CRC status is latched on the positive edge only, and don't care on the negative edge.

#### 6.3.3. Command (CMD)

This signal is a bidirectional command channel used for Device initialization and transfer of commands. The CMD signal has two operation modes: open-drain for initialization mode, and push-pull for fast command transfer. Commands are sent from the *eMMC* host controller to the *eMMC* Device and responses are sent from the Device to the host.

#### 6.3.4. Input/Outputs (DAT0-DAT7)

These are bidirectional data channels. The DAT signals operate in push-pull mode. Only the Device or the host is driving these signals at a time. By default, after power up or reset, only DAT0 is used for data transfer. A wider data bus can be configured for data transfer, using either DAT0-DAT3 or DAT0- DAT7, by the *eMMC* host controller. The *eMMC* Device includes internal pull-ups for data lines DAT1- DAT7. Immediately after entering the 4-bit mode, the Device disconnects the internal pull ups of lines DAT1, DAT2, and DAT3. Correspondingly, immediately after entering to the 8-bit mode the Device disconnects the internal pull-ups of lines DAT1–DAT7.

Table 5 – Communication Interface

Name	Type <sup>1</sup>	Description
CLK	I	Clock
DAT0	I/O/PP	Data
DAT1	I/O/PP	Data
DAT2	I/O/PP	Data
DAT3	I/O/PP	Data
DAT4	I/O/PP	Data
DAT5	I/O/PP	Data
DAT6	I/O/PP	Data
DAT7	I/O/PP	Data
CMD	I/O/PP/OD	Command/Response
RST_n	I	Hardware reset
VCC	S	Supply voltage for core
VCCQ	S	Supply voltage for I/O
VSS	S	Supply voltage ground for core
VSSQ	S	Supply voltage ground for I/O
DS	O/PP	Data strobe
VDDi		Connect capacitor from VDDi to GND for stabilize internal power
<p><b>Note:</b> I: input; O: output; PP: push-pull; OD: open-drain; NC: Not connected (or logical high); S: power supply.</p>		

## 7. eMMC Functional Description ■ ■ ■

### 7.1. Pseudo Technology (pSLC)

Each cell in an TLC NAND can be programmed to store 3 bits of data with 8 total voltage states. In Pseudo-SLC (pSLC) mode, the memory cell is used in 2-bit or 1-bit mode, thus resulting in higher endurance, lower error rates and extended temperature range. Phison firmware optimizes the eMMC device with Pseudo technology to achieve industrial and automotive level reliability. For Phison eMMC device, Pseudo SLC (pSLC) mode provides one quarter capacity of TLC mode.

### 7.2. Field Firmware Update (FFU)

Field Firmware Updates (FFU) enables features enhancement in the field. Using this mechanism the host downloads a new version of the firmware to the eMMC device and, following a successful download, instructs the eMMC device to install the new downloaded firmware into the device.

In order to start the FFU process the host first checks if the eMMC device supports FFU capabilities by reading SUPPORTED\_MODES and FW\_CONFIG fields in the EXT\_CSD. If the eMMC device supports the FFU feature the host may start the FFU process. The FFU process starts by switching to FFU Mode in MODE\_CONFIG field in the EXT\_CSD. In FFU Mode host should use closed-ended or open ended commands for downloading the new firmware and reading vendor proprietary data. In this mode, the host should set the argument of these commands to be as defined in FFU\_ARG field. In case these commands have a different argument the device behavior is not defined and the FFU process may fail. The host should set Block Length to be DATA\_SECTOR\_SIZE. Downloaded firmware bundle must be DATA\_SECTOR\_SIZE size aligned (internal padding of the bundle might be required). Once in FFU Mode the host may send the new firmware bundle to the device using one or more write commands.

The host could regain regular functionality of write and read commands by setting MODE\_CONFIG field in the EXT\_CSD back to Normal state. Switching out of FFU Mode may abort the firmware download operation. When host switched back to FFU Mode, the host should check the FFU Status to get indication about the number of sectors which were downloaded successfully by reading the NUMBER\_OF\_FW\_SECTORS\_CORRECTLY\_PROGRAMMED in the extended CSD. In case the number of sectors which were downloaded successfully is zero the host should re-start downloading the new firmware bundle from its first sector. In case the number of sectors which were downloaded successfully is positive the host should continue the download from the next sector, which would resume the firmware download operation.

**UD info CORP. TEL: +886-2-7713-6050 FAX: +886-2-8511-3151**

*3F-4, No.8, Ln. 609, Sec. 5, Chongxin Rd., Sanchong Dist., New Taipei City 241, Taiwan (R.O.C.)*



In case `MODE_OPERATION_CODES` field is not supported by the device the host sets to `NORMAL` state and initiates a `CMD0/HW_Reset/Power` cycle to install the new firmware. In such case the device doesn't need to use `NUMBER_OF_FW_SECTORS_CORRECTLY_PROGRAMMED`. In both cases occurrence of a `CMD0/HW_Reset/Power` occurred before the host successfully downloaded the new firmware bundle to the device may cause the firmware download process to be aborted.

### 7.3. Power off Notification for sleep

The host should notify the device before it powers the device off. This allows the device to better prepare itself for being powered off. Power the device off means to turn off all its power supplies. In particular, the host should issue a power off notification (`POWER_OFF_LONG`, `POWER_OFF_SHORT`) if it intends to turn off both `VCC` and `VCCQ` power or it may use to a power off notification (`SLEEP_NOTIFICATION`) if it intends to turn-off `VCC` after moving the device to Sleep state.

To indicate to the device that power off notification is supported by the host, a supporting host shall first set the `POWER_OFF_NOTIFICATION` byte in `EXT_CSD [34]` to `POWERED_ON (0x01)`. To execute a power off, before powering the device down the host will change the value to either `POWER_OFF_SHORT (0x02)` or `POWER_OFF_LONG (0x03)`. Host should wait for the busy line to be de-asserted. Once the setting has changed to either `0x02` or `0x03`, host may safely power off the device.

The host may issue `SLEEP_AWAKE (CMD5)` to enter or to exit from Sleep state if `POWER_OFF_NOTIFICATION` byte is set to `POWERED_ON`. Before moving to Standby state and then to Sleep state, the host sets `POWER_OFF_NOTIFICATION` to `SLEEP_NOTIFICATION` and waits for the `DAT0` line de-assertion. While in Sleep (`slp`) state `VCC` (Memory supply) may be turned off as defined in 4.1.6. Removing power supplies other than `VCC` while the device is in the Sleep (`slp`) state may result in undefined device behavior. Before removing all power supplies, the host should transition the device out of Sleep (`slp`) state back to Transfer state using `CMD5` and `CMD7` and then execute a power off notification setting `POWER_OFF_NOTIFICATION` byte to either `POWER_OFF_SHORT` or `POWER_OFF_LONG`.

If host continues to send commands to the device after switching to the power off setting (`POWER_OFF_LONG`, `POWER_OFF_SHORT` or `SLEEP_NOTIFICATION`) or performs HPI during its busy condition, the device shall restore the `POWER_OFF_NOTIFICATION` byte to `POWERED_ON`.

If host tries to change `POWER_OFF_NOTIFICATION` to `0x00` after writing another value there, a `SWITCH_ERROR` is generated.

**UD info CORP. TEL: +886-2-7713-6050 FAX: +886-2-8511-3151**

*3F-4, No.8, Ln. 609, Sec. 5, Chongxin Rd., Sanchong Dist., New Taipei City 241, Taiwan (R.O.C.)*

The difference between the two power-off modes is how urgent the host wants to turn power off. The device should respond to POWER\_OFF\_SHORT quickly under the generic CMD6 timeout. If more time is acceptable, POWER\_OFF\_LONG may be used and the device shall respond to it within the POWER\_OFF\_LONG\_TIME timeout.

While POWER\_OFF\_NOTIFICATION is set to POWERED\_ON, the device expects the host to host shall:

- Keep the device power supplies alive (both V<sub>CC</sub> and V<sub>CCQ</sub>) and in their active mode
- Not power off the device intentionally before changing POWER\_OFF\_NOTIFICATION to either POWER\_OFF\_LONG or POWER\_OFF\_SHORT
- Not power off V<sub>CC</sub> intentionally before changing POWER\_OFF\_NOTIFICATION to SLEEP\_NOTIFICATION and before moving the device to Sleep state

Before moving to Sleep state hosts may set the POWER\_OFF\_NOTIFICATION byte to SLEEP\_NOTIFICATION (0x04) if aware that the device is capable of autonomously initiating background operations for possible performance improvements. Host should wait for the busy line to be de-asserted. Busy line may be asserted up the period defined in SLEEP\_NOTIFICATION\_TIME byte in EXT\_CSD [216]. Once the setting has changed to 0x04 host may set the device into Sleep mode (CMD7+CMD5). After getting out from Sleep the POWER\_OFF\_NOTIFICATION byte will restore its value to POWERED\_ON. HPI may interrupt the SLEEP\_NOTIFICATION operation. In that case POWER\_OFF\_NOTIFICATION byte will restore to POWERED\_ON.

## 7.4. Enhanced User Data Area

UDinfo eMMC supports Enhanced User Data Area feature which allows the User Data Area of eMMC to be configured as SLC Mode. Therefore, when host set the Enhanced User Data Area, the area will occupy double size of original set up size. The Max Enhanced User Data Area size is defined as - (MAX\_ENH\_SIZE\_MULT x HC\_WP\_GRP\_SIZE x HC\_ERASE\_GRP\_SIZE x 512 KBytes). The Enhanced use data area size is defined as - (ENH\_SIZE\_MULT x HC\_WP\_GRP\_SIZE x HC\_ERASE\_GRP\_SIZE x 512 KBytes). The host shall follow the flow chart of JEDEC spec for configuring the parameters of General Purpose Area Partitions and Enhanced User Data Area.

## 7.5. Write Cache

Cache is a temporary storage space in an eMMC device. The cache should in typical case reduce the access time and increase the speed (compared to an access to the main nonvolatile storage). The cache is not directly accessible by the host. This temporary storage space may be utilized also for some implementation specific operations like as an execution memory for the memory

**UD info CORP. TEL: +886-2-7713-6050 FAX: +886-2-8511-3151**

*3F-4, No.8, Ln. 609, Sec. 5, Chongxin Rd., Sanchong Dist., New Taipei City 241, Taiwan (R.O.C.)*

controller and/or as storage for an address mapping table etc. However, there is data inconsistency risk when using nonvolatile cache. It's recommend only turning on the cache for the application which requires not too high reliability.

The cache shall be OFF by default after power up, RSTn assertion or CMD0. All accesses shall be directed to the nonvolatile storage like defined elsewhere in this specification. The cache function can be turned ON and OFF by writing to the CACHE\_CTRL byte (EXT\_CSD byte [33]). Turning the cache ON shall enable behavior model defined in this section. Turning the cache OFF shall trigger flushing of the data to the nonvolatile storage.

## 7.6. Cache Enhancement Barrier

Barrier function provides a way to perform a delayed in-order flushing of a cached data. The main motivation for using barrier commands is to avoid the long delay that is introduced by flush commands. There are cases where the host is not interested in flushing the data right away, however it would like to keep an order between different cached data batches. The barrier command enables the host achieving the in-order goal but without paying the flush delay, since the real flushing can be delayed by the device to some later idle time. The formal definition of the barrier rule is as follows:

Denote a sequence of requests  $R_i$ ,  $i=0,..,N$ . Assuming a barrier is set between requests  $R_x$  and  $R_{x+1}$  ( $0 < x < N$ ) then all the requests  $R_0..R_x$  must be flushed to the non-volatile memory before any of the requests  $R_{x+1}..R_N$ .

Between two barriers the device is free to write data into the non-volatile memory in any order. If the host wants to preserve a certain order it shall flush the cache or set another barrier at a point where order is important.

The barrier is set by writing to the BARRIER bit of the FLUSH\_CACHE byte (EXT\_CSD byte [32]). Any error resulted can be read from the status register by CMD13 after the completion of the programming as defined for a normal write request. The error could affect any data written to the cache since the previous flush operation.

The device shall support any number of barrier commands between two flush commands. In case of multiple barrier commands between two flush commands a subset of the cached data may be committed to the non-volatile memory according to the barrier rule. Internally, a device may have an upper limit on the barrier amount it can absorb without flushing the cache. That is, if the host exceeds this barrier amount, the device may issue, internally, a normal flush.

The device shall expose its barrier support capability via the BARRIER\_SUPPORT byte (EXT\_CSD byte [486]). If a device does not support barrier function this register shall be zero. If a device supports barrier function this register shall be one.

**UD info CORP. TEL: +886-2-7713-6050 FAX: +886-2-8511-3151**

*3F-4, No.8, Ln. 609, Sec. 5, Chongxin Rd., Sanchong Dist., New Taipei City 241, Taiwan (R.O.C.)*

Assuming the device supports barrier function, if the BARRIER bit of the FLUSH\_CACHE byte is set, a barrier operation shall be executed.

If the cache gets totally full and/or the cache is not able to receive the data of the next access (per block count indicated in CMD23 or per initiated single / open ended multiple block write in general) then it shall still be the responsibility of the eMMC device to store the data of the next access within the timeouts that are specified elsewhere in this specification. The actual algorithm to handle the new data and possible flush of some older cached data is left for the implementation.

Note: When issuing a force-programming write request (CMD23 with bit 24 on) or a reliable write request (CMD23 with bit 31 on), the host should be aware that the data will be written to the non-volatile memory, potentially, before any cached data, even if a barrier command was issued. Therefore, if the writing order to the non-volatile memory is important, it is the responsibility of the host to issue a flush command before the force-programming or the reliable-write request.

In order to use the barrier function, the host shall set bit 0 of BARRIER\_EN (EXT\_CSD byte [31]). The barrier feature is optional for an eMMC device.

## 7.7. Cache Flushing Policy

The host may require the device to flush data from the cache in an in-order manner. From time to time, to guarantee in-order flushing, the host may command the device to flush the device cache or may use a barrier command.

However, if the eMMC device flushing policy is to flush data from the cache in an in-order manner, cache barrier commands or flush commands operations (In case goal is to guarantee the flushing order) are redundant and impose a needless overhead to the device and host.

FIFO bit in CACHE\_FLUSH\_POLICY field (EXT\_CSD byte [240]) is used by the device to indicate to the host that the device cache flushing policy is First-In-First-Out; this means that the device guarantees that the order of the flushing of data would be the in same order which data was written to the cache. When the FIFO bit is set it is recommended for the host not to send cache barrier commands or flush operations which goal is to guarantee the flushing order as they are redundant and impose a burden to the system.

However, if the FIFO bit is set to 1b and the device supports the cache barrier mechanism, the host may still send barrier commands without getting an error. Sending these commands will not change the device behavior as device flushes cache in-order anyway.

The CACHE\_FLUSH\_POLICY field is read-only field and never change its value either by the host or device.

## 7.8. Command Queuing (Disabled by default)

To facilitate command queuing in eMMC, the device manages an internal task queue to which the host can queue data transfer tasks.

Initially the task queue is empty. Every task is issued by the host and initially queued as pending. The device controller works to prepare pending tasks for execution. When a task is ready for execution its state changes to “ready for execution”. The exact meaning of “ready for execution” is left for device implementation.

The host tracks the state of all queued tasks and may order the execution of any task, which is marked as “ready for execution” by sending a command indicating its task ID. When the execute command is received (CMD46/CMD47) the device executes the data transfer transaction.

For example, in order to queue a write transaction the host sends a CMD44 indicating the task’s parameters. The device responds and the host sends a CMD45, indicating the start block address.

The device regards the two commands as a single task in the queue and sends a response indicating success if no error is detected. This exchange may be executed on the CMD line while a data transfer, or busy state, is ongoing on the DAT lines. The host tracks the state of the queue using CMD13.

At a later time, when data transfer is not in progress, the host issues a CMD47, ordering the device to execute a task from the queue, providing the Task ID in its argument. The device responds with an R1 response and the data transfer starts.

Note that if hosts need to access RPMB partition, the host should disable the Command Queue mechanism and access RPMB partition not through the command queue.

General Purpose partitions may be accessed when command queuing is enabled.

The queue must be empty when CMD6 is sent (to switch partitions or to disable command queuing).

Sending CMD6 while the queue is not empty shall be regarded as illegal command (as explained 6.6.42.9 Supported Commands).

Prior to enabling command queuing, the block size shall be set to 512B. Device may respond with an error to CMD46/CMD47 if block size is not 512B.

## 7.9. Production State Awareness (PSA)

eMMC device could utilize the information of whether it is in production environment and operate differently than it operates in the field.

For example, content that was loaded into the storage device prior to soldering might get corrupted, at higher probability, during device soldering. The eMMC device could use “special”

**UD info CORP. TEL: +886-2-7713-6050 FAX: +886-2-8511-3151**

*3F-4, No.8, Ln. 609, Sec. 5, Chongxin Rd., Sanchong Dist., New Taipei City 241, Taiwan (R.O.C.)*

internal operations for loading content prior to device soldering that would reduce production failures and use “regular” operations post-soldering.

PRODUCTION\_STATE\_AWARENESS [133] field in extended CSD is used as a mechanism through which the host should report to the device whether it is pre or post soldering state.

This standard defines two methods, Manual Mode and Auto Mode, to manage the device production state.

The trigger for starting or re-starting the process is setting correctly PRE\_LOADING\_DATA\_SIZE field. Before setting this field the host is expected to make sure that the device is clean and any data that was written before to the device is expected to be erased using CMD35, CMD36 and CMD38.

In case the host erased data, overrode existing data or performed re-partition during production state awareness it should restart the production state awareness process by re-setting PRE\_LOADING\_DATA\_SIZE.

UDinfo defines Pseudo SLC mode as special internal operation of PSA to have better reliability during the soldering process in production (reflow). UDinfo has adopted mechanisms to recover the TLC behavior after the end of production. Once the host used over the threshold, the PSA feature is disabled and the firmware will start to merge pSLC blocks to TLC block to make drive returns to original situation. Threshold values of PSA are different according to NAND mode:

- TLC – 33% of user capacity

## 8. Register Settings

Within the Device interface six registers are defined: OCR, CID, CSD, EXT\_CSD, RCA and DSR. These can be accessed only by corresponding commands (see Section 6.10 of JESD84-B51).

### 8.1. OCR Register

The 32-bit operation conditions register (OCR) stores the VDD voltage profile of the Device and the access mode indication. In addition, this register includes a status information bit. This status bit is set if the Device power up procedure has been finished. The OCR register shall be implemented by all Devices.

OCR bit	VDD voltage window	High Voltage Value	Dual Voltage Value
[6:0]	Reserved	00 00000b	00 00000b
[7]	1.70 - 1.95V	0b	1b
[14:8]	2.0-2.7V	000 0000b	000 0000b
[23:15]	2.7-3.6V	1 1111 1111b	1 1111 1111b
[28:24]	Reserved	0 0000b	0 0000b
[30:29]	Access Mode	00b (byte mode) 10b (sector mode)	00b (byte mode) 10b (sector mode)
[31]	Device power up status bit (busy) <sup>1</sup>		

Note1 : This bit is set to LOW if the Device has not finished the power up routine.

### 8.2. CID Register

The Card Identification (CID) register is 128 bits wide. It contains the Device identification information used during the Device identification phase (eMMC protocol). For details, refer to JEDEC Standard Specification No.JESD84-B51

CID Fields Name	Field	Width	CID slice	Value
Manufacturer ID	MID	8	[127:120]	32h
Reserved		6	[119:114]	0h
Device/BGA	CBX	2	[113:112]	1h
OEM/Application ID	OID	8	[111:104]	1h
Product name	PNM	48	[103:56]	16GB - 4D4D43313647h "MMC16G" 32GB - 4D4D43333247h "MMC32G" 64GB - 4D4D43363447h "MMC64G" 128GB - 4D4D43313238h "MMC128"
Product revision	PRV	8	[55:48]	51h*
Product serial number	PSN	32	[47:16]	Random by Production
Manufacturing date	MDT	8	[15:8]	Month, Year
CRC7 checksum	CRC	7	[7:1]	-(Note 1)
not used, always "1"	-	1	[0]	1h

Note1 : The description are same as e.MMC™ JEDEC standard.

**UD info CORP. TEL: +886-2-7713-6050 FAX: +886-2-8511-3151**

3F-4, No.8, Ln. 609, Sec. 5, Chongxin Rd., Sanchong Dist., New Taipei City 241, Taiwan (R.O.C.)

### 8.3. CSD Register

The Card-Specific Data (CSD) register provides information on how to access the contents stored in eMMC. The CSD registers are used to define the error correction type, maximum data access time, data transfer speed, data format...etc. For details, refer to section 7.3 of the JEDEC Standard Specification No. JESD84-B51.

Name	Field	Width	Cell Type	CSD-slice	Value
CSD structure	CSD_STRUCTURE	2	R	[127:126]	3h
System specification version	SPEC_VERS	4	R	[125:122]	4h
Reserved	-	2	R	[121:120]	0h
Data read access-time 1	TAAC	8	R	[119:112]	4Fh
Data read access-time 2 in CLK cycles (NSAC*100)	NSAC	8	R	[111:104]	1h
Max. bus clock frequency	TRAN_SPEED	8	R	[103:96]	32h
Device command classes	CCC	12	R	[95:84]	8F5h
Max. read data block length	READ_BL_LEN	4	R	[83:80]	9h
Partial blocks for read allowed	READ_BL_PARTIAL	1	R	[79:79]	0h
Write block misalignment	WRITE_BLK_MISALIGN	1	R	[78:78]	0h
Read block misalignment	READ_BLK_MISALIGN	1	R	[77:77]	0h
DSR implemented	DSR_IMP	1	R	[76:76]	0h
Reserved	-	2	R	[75:74]	0h
Device size	C_SIZE	12	R	[73:62]	FFFh
Max. read current @ VDD min	VDD_R_CURR_MIN	3	R	[61:59]	7h
Max. read current @ VDD max	VDD_R_CURR_MAX	3	R	[58:56]	7h
Max. write current @ VDD min	VDD_W_CURR_MIN	3	R	[55:53]	7h
Max. write current @ VDD max	VDD_W_CURR_MAX	3	R	[52:50]	7h
Device size multiplier	C_SIZE_MULT	3	R	[49:47]	7h
Erase group size	ERASE_GRP_SIZE	5	R	[46:42]	1Fh
Erase group size multiplier	ERASE_GRP_MULT	5	R	[41:37]	1Fh
Write protect group size	WP_GRP_SIZE	5	R	[36:32]	0Fh
Write protect group enable	WP_GRP_ENABLE	1	R	[31:31]	1h
Manufacturer default ECC	DEFAULT_ECC	2	R	[30:29]	0h
Write speed factor	R2W_FACTOR	3	R	[28:26]	2h
Max. write data block length	WRITE_BL_LEN	4	R	[25:22]	9h
Partial blocks for write allowed	WRITE_BL_PARTIAL	1	R	[21:21]	0h
Reserved	-	4	R	[20:17]	0h
Content protection application	CONTENT_PROT_APP	1	R	[16:16]	0h
File format group	FILE_FORMAT_GRP	1	R/W	[15:15]	0h
Copy flag (OTP)	COPY	1	R/W	[14:14]	0h
Permanent write protection	PERM_WRITE_PROTECT	1	R/W	[13:13]	0h
Temporary write protection	TMP_WRITE_PROTECT	1	R/W/E	[12:12]	0h
File format	FILE_FORMAT	2	R/W	[11:10]	0h
ECC code	ECC	2	R/W/E	[9:8]	0h
CRC	CRC	7	R/W/E	[7:1]	2Eh
Reserved	-	1	-	[0:0]	1h

**UD info CORP. TEL: +886-2-7713-6050 FAX: +886-2-8511-3151**

*3F-4, No.8, Ln. 609, Sec. 5, Chongxin Rd., Sanchong Dist., New Taipei City 241, Taiwan (R.O.C.)*



## 8.4. Extended CSD Register

The Extended CSD register defines the Device properties and selected modes. It is 512 bytes long. The most significant 320 bytes are the Properties segment, which defines the Device capabilities and cannot be modified by the host. The lower 192 bytes are the Modes segment, which defines the configuration the Device is working in. These modes can be changed by the host by means of the SWITCH command.

Name	Field	Size (Bytes)	CSD-slice	Value
Reserved	-	6	[511:506]	0h
Extended Security Commands Error	EXT_SECURITY_ERR	1	[505]	0h
Supported Command Sets	S_CMD_SET	1	[504]	1h
HPI features	HPI_FEATURES	1	[503]	1h
Background operations support	BKOPS_SUPPORT	1	[502]	1h
Max packed read commands	MAX_PACKED_READS	1	[501]	20h
Max packed write commands	MAX_PACKED_WRITES	1	[500]	20h
Data Tag Support	DATA_TAG_SUPPORT	1	[499]	1h
Tag Unit Size	TAG_UNIT_SIZE	1	[498]	3h
Tag Resources Size	TAG_RES_SIZE	1	[497]	0h
Context management capabilities	CONTEXT_CAPABILITIES	1	[496]	5h
Large Unit size	LARGE_UNIT_SIZE_M1	1	[495]	18h
Extended partitions attribute support	EXT_SUPPORT	1	[494]	3h
Supported modes	SUPPORTED_MODES	1	[493]	3h
FFU features	FFU_FEATURES	1	[492]	0h
Operation codes timeout	OPERATION_CODE_TIME_OUT	1	[491]	0h
FFU Argument	FFU_ARG	4	[490:487]	0h
Barrier support	BARRIER_SUPPORT	1	[486]	0h
Reserved	Reserved	177	[486:309]	-
CMDQ support	CMDQ_SUPPORT	1	[308]	1h
CMDQ depth	CMDQ_DEPTH	1	[307]	1Fh
Reserved	Reserved	1	[306]	-
Number of FW sectors correctly programmed	NUMBER_OF_FW_SECTORS_CORRECTLY_PROGRAMMED	4	[305:302]	0h
Vendor proprietary health report	VENDOR_PROPRIETARY_HEALTH_REPORT	32	[301:270]	-
Device life time estimation type B	DEVICE_LIFE_TIME_EST_TYP_B	1	[269]	1h
Device life time estimation type A	DEVICE_LIFE_TIME_EST_TYP_A	1	[268]	1h
Pre EOL information	PRE_EOL_INFO	1	[267]	1h
Optimal read size	OPTIMAL_READ_SIZE	1	[266]	1h
Optimal write size	OPTIMAL_WRITE_SIZE	1	[265]	8h
Optimal trim unit size	OPTIMAL_TRIM_UNIT_SIZE	1	[264]	1h
Device version	DEVICE_VERSION	2	[263:262]	0h
Firmware version	FIRMWARE_VERSION	8	[261:254]	0h*
Power class for 200MH, DRR at VCC=3.6V	PWR_CL_DDR_200_360	1	[253]	0h
Cache size	CACHE_SIZE	4	[252:249]	1536
Generic CMD6 timeout	GENERIC_CMD6_TIME	1	[248]	Ah

**UD info CORP. TEL: +886-2-7713-6050 FAX: +886-2-8511-3151**

*3F-4, No.8, Ln. 609, Sec. 5, Chongxin Rd., Sanchong Dist., New Taipei City 241, Taiwan (R.O.C.)*

Name	Field	Size (Bytes)	CSD-slice	Value
Power off notification(long) timeout	POWER_OFF_LONG_TIME	1	[247]	32h
Background operations status	BKOPS_STATUS	1	[246]	0h
Number of correctly programmed sectors	CORRECTLY_PRG_SECTORS_NUM	4	[245:242]	0h
1st initialization time after partitioning	INI_TIMEOUT_AP	1	[241]	1Eh
Cache Flushing Policy	CACHE_FLUSH_POLICY	1	[240]	1h
Power class for 52MHz, DDR at 3.6V	PWR_CL_DDR_52_360	1	[239]	0h
Power class for 52MHz, DDR at 1.95V	PWR_CL_DDR_52_195	1	[238]	0h
Power class for 200MHz at 3.6V	PWR_CL_200_360	1	[237]	0h
Power class for 200MHz, at 1.95V	PWR_CL_200_195	1	[236]	0h
Minimum Write Performance for 8bit at 52MHz in DDR mode	MIN_PERF_DDR_W_8_52	1	[235]	4Bh
Minimum Read Performance for 8bit at 52MHz in DDR mode	MIN_PERF_DDR_R_8_52	1	[234]	0h
Reserved	-	1	[233]	0h
TRIM Multiplier	TRIM_MULT	1	[232]	12h
Secure Feature support	SEC_FEATURE_SUPPORT	1	[231]	55h
Secure Erase Multiplier	SEC_ERASE_MULT	1	[230]	64h
Secure TRIM Multiplier	SEC_TRIM_MULT	1	[229]	64h
Boot information	BOOT_INFO	1	[228]	7h
Reserved	-	1	[227]	0h
Boot partition size	BOOT_SIZE_MULTI	1	[226]	20h
Access size	ACC_SIZE	1	[225]	7h - TLC 16GB / pSLC 8GB 7h - TLC 32GB 8h - TLC 64GB / pSLC 16GB 9h - TLC 128GB / pSLC 32GB
High-capacity erase unit size	HC_ERASE_GRP_SIZE	1	[224]	1h
High-capacity erase timeout	ERASE_TIMEOUT_MULT	1	[223]	12h
Reliable write sector count	REL_WR_SEC_C	1	[222]	1h
High-capacity write protect group size	HC_WP_GRP_SIZE	1	[221]	10h
Sleep current (VCC)	S_C_VCC	1	[220]	8h
Sleep current (VCCQ)	S_C_VCCQ	1	[219]	8h
Production state awareness Timeout	PRODUCTION_STATE_AWARENESS_TIMEOUT	1	[218]	0h
Sleep/awake timeout	S_A_TIMEOUT	1	[217]	15h
Sleep Notification timeout	SLEEP_NOTIFICATION_TIME	1	[216]	0Fh
Sector Count	SEC_COUNT	4	[215:212]	15267840 - 8GB 30535680 - 16GB 61071360 - 32GB 122142720 - 64GB 244285440 - 128GB
Security write protect information	SECURE_WP_INFO	1	[211]	1h

**UD info CORP. TEL: +886-2-7713-6050 FAX: +886-2-8511-3151**

3F-4, No.8, Ln. 609, Sec. 5, Chongxin Rd., Sanchong Dist., New Taipei City 241, Taiwan (R.O.C.)

Name	Field	Size (Bytes)	CSD-slice	Value
Minimum Write Performance for 8bit at 52MHz	MIN_PERF_W_8_52	1	[210]	4Bh
Minimum Read Performance for 8bit at 52MHz	MIN_PERF_R_8_52	1	[209]	0h
Minimum Write Performance for 8bit at 26MHz, for 4bit at 52MHz	MIN_PERF_W_8_26_4_52	1	[208]	2Bh
Minimum Read Performance for 8bit at 26MHz, for 4bit at 52MHz	MIN_PERF_R_8_26_4_52	1	[207]	0h
Minimum Write Performance for 4bit at 26MHz	MIN_PERF_W_4_26	1	[206]	1Eh
Minimum Read Performance for 4bit at 26MHz	MIN_PERF_R_4_26	1	[205]	0h
Reserved	-	1	[204]	0h
Power class for 26MHz at 3.6V 1 R	PWR_CL_26_360	1	[203]	0h
Power class for 52MHz at 3.6V 1 R	PWR_CL_52_360	1	[202]	0h
Power class for 26MHz at 1.95V 1 R	PWR_CL_26_195	1	[201]	0h
Power class for 52MHz at 1.95V 1 R	PWR_CL_52_195	1	[200]	0h
Partition switching timing	PARTITION_SWITCH_TIME	1	[199]	3h
Out-of-interrupt busy timing	OUT_OF_INTERRUPT_TIME	1	[198]	Ah
I/O Driver Strength	DRIVER_STRENGTH	1	[197]	1Fh
Device type	CARD_TYPE	1	[196]	57h
Reserved	-	1	[195]	-
CSD structure version	-	1	[194]	2h
Reserved	-	1	[193]	0h
Extended CSD revision	EXT_CSD_REV	1	[192]	8h
Command set	CMD_SET	1	[191]	0h
Reserved	-	1	[190]	-
Command set revision	CMD_SET_REV	1	[189]	0h
Reserved	-	1	[188]	-
Power class	POWER_CLASS	1	[187]	0h
Reserved	-	1	[186]	-
High-speed interface timing	HS_TIMING	1	[185]	1h (note 3)
Strobe support	STROBE_SUPPORT	1	[184]	1h
Bus width mode	BUS_WIDTH	1	[183]	2h (note 4)
Reserved	-	1	[182]	-
Erased memory content	ERASED_MEM_CONT	1	[181]	0h
Reserved	-	1	[180]	-
Partition configuration	PARTITION_CONFIG	1	[179]	0h
Boot config protection	BOOT_CONFIG_PROT	1	[178]	0h
Boot bus Conditions	BOOT_BUS_CONDITIONS	1	[177]	0h
Reserved	-	1	[176]	-
High-density erase group definition	ERASE_GROUP_DEF	1	[175]	0h
Boot write protection status registers	BOOT_WP_STATUS	1	[174]	0h
Boot area write protection register	BOOT_WP	1	[173]	0h
Reserved	-	1	[172]	-
User area write protection register	USER_WP	1	[171]	0h
Reserved	-	1	[170]	-
FW configuration	FW_CONFIG	1	[169]	0h
RPMB Size	RPMB_SIZE_MULT	1	[168]	20h

**UD info CORP. TEL: +886-2-7713-6050 FAX: +886-2-8511-3151**

3F-4, No.8, Ln. 609, Sec. 5, Chongxin Rd., Sanchong Dist., New Taipei City 241, Taiwan (R.O.C.)

Name	Field	Size (Bytes)	CSD-slice	Value
Write reliability setting register	WR_REL_SET	1	[167]	1Fh
Write reliability parameter register	WR_REL_PARAM	1	[166]	15h
Start Sanitize operation	SANITIZE_START	1	[165]	0h
Manually start background operations	BKOPS_START	1	[164]	0h
Enable background operations handshake	BKOPS_EN	1	[163]	0h
H/W reset function	RST_n_FUNCTION	1	[162]	0h
HPI management	HPI_MGMT	1	[161]	0h
Partitioning Support	PARTITIONING_SUPPORT	1	[160]	7h
Max Enhanced Area Size	MAX_ENH_SIZE_MULT	3	[159:157]	618-TLC 16GB 1242-TLC 32GB 2484-TLC 64GB 4968-TLC 128GB 936-pSLC 8GB 1872-pSLC 16GB 3744-pSLC 32GB
Partitions attribute	PARTITIONS_ATTRIBUTE	1	[156]	0h
Partitioning Setting	PARTITION_SETTING_COMPLETED	1	[155]	0h
General Purpose Partition Size	GP_SIZE_MULT4	3	[154:152]	0h
General Purpose Partition Size	GP_SIZE_MULT3	3	[151:149]	0h
General Purpose Partition Size	GP_SIZE_MULT2	3	[148:146]	0h
General Purpose Partition Size	GP_SIZE_MULT1	3	[145:143]	0h
Enhanced User Data Area Size	ENH_SIZE_MULT	3	[142:140]	618-TLC 16GB 1242-TLC 32GB 2484-TLC 64GB 4968-TLC 128GB 936-pSLC 8GB 1872-pSLC 16GB 3744-pSLC 32GB
Enhanced User Data Start Address	ENH_START_ADDR	4	[139:136]	0h
Reserved	–	1	[135]	0h
Bad Block Management mode	SEC_BAD_BLK_MGMNT	1	[134]	0h
Production state awareness	PRODUCTION_STATE_AWARENESS	1	[133]	0h
Package Case Temperature is controlled	TCASE_SUPPORT	1	[132]	0h
Periodic Wake-up	PERIODIC_WAKEUP	1	[131]	0h
Program CID/CSD in DDR mode support	PROGRAM_CID_CSD_DDR_SUPPORT	1	[130]	1h
Reserved	–	2	[129:128]	0h
Vendor Specific Fields	VENDOR_SPECIFIC_FIELD	61	[127:67]	–
Error code	ERROR_CODE	2	[66:65]	0h
Error type	ERROR_TYPE	1	[64]	0h
Native sector size	NATIVE_SECTOR_SIZE	1	[63]	0h
Sector size emulation	USE_NATIVE_SECTOR	1	[62]	0h
Sector size	DATA_SECTOR_SIZE	1	[61]	0h
1st initialization after disabling sector size emulation	INI_TIMEOUT_EMU	1	[60]	0h
Class 6 commands control	CLASS_6_CTRL	1	[59]	0h

**UD info CORP. TEL: +886-2-7713-6050 FAX: +886-2-8511-3151**

3F-4, No.8, Ln. 609, Sec. 5, Chongxin Rd., Sanchong Dist., New Taipei City 241, Taiwan (R.O.C.)

Name	Field	Size (Bytes)	CSD-slice	Value
Number of addressed group to be Released	DYNCAP_NEEDED	1	[58]	0h
Exception events control	EXCEPTION_EVENTS_CTRL	2	[57:56]	0h
Exception events status	EXCEPTION_EVENTS_STATUS	2	[55:54]	0h
Extended Partitions Attribute	EXT_PARTITIONS_ATTRIBUTE	2	[53:52]	0h
Context configuration	CONTEXT_CONF	15	[51:37]	0h
Packed command status	PACKED_COMMAND_STATUS	1	[36]	0h
Packed command failure index	PACKED_FAILURE_INDEX	1	[35]	0h
Power Off Notification	POWER_OFF_NOTIFICATION	1	[34]	0h
Control to turn the Cache ON/OFF	CACHE_CTRL	1	[33]	0h
Flushing of the cache	FLUSH_CACHE	1	[32]	0h
Reserved	Reserved	1	[31]	0h
Mode config	MODE_CONFIG	1	[30]	0h
Mode operation codes	MODE_OPERATION_CODES	1	[29]	0h
Reserved	Reserved	2	[28:27]	0h
FFU status	FFU_STATUS	1	[26]	0h
Per loading data size	PRE_LOADING_DATA_SIZE	4	[25:22]	0h
Max pre loading data size	MAX_PRE_LOADING_DATA_SIZE	4	[21:18]	TLC: 16GB: 9932800 32GB: 20111360 64GB: 40222720 128GB: 80445440 pSLC: 8GB: 15267840 16GB: 30535680 32GB: 61071360
Product state awareness enablement	PRODUCT_STATE_AWARENESS_ENABLEMENT	1	[17]	1h
Secure removal type	SECURE_REMOVAL_TYPE	1	[16]	1h
Command Queue Mode enable	CMQ_MODE_EN	1	[15]	0h
Reserved	Reserved	15	[14:0]	–
<p>Note1 : Reserved bits should read as “0.”</p> <p>Note2 : Obsolete values should be don’t care.</p> <p>Note3 : This field is 0 after power-on, H/W reset or software reset, thus selecting the backwards compatibility interface timing for the Device. If the host sets 1 to this field, the Device changes its timing to high speed interface timing (see Section 10.6.1 of JESD84-B50). If the host sets value 2 the Device changes its timing to HS200 interface timing (see Section 10.8.1 of JESD84-B50), If the host sets HS_TIMING[3:0] to 0x3, the device changes its timing to HS400 interface timing (see 10.10).</p> <p>Note4 : It is set to ‘0’ (1 bit data bus) after power up and can be changed by a SWITCH command.</p> <p>Note5 : * Changed by Firmware release note.</p> <p>Note6 : The values of Device version, Cache size, Sector Count, Max Enhanced Area Size, Enhanced User Data Area Size and Max pre loading data size are expressed in Decimal, while the value of h is the abbreviation of Hexadecimal.</p>				

**UD info CORP. TEL: +886-2-7713-6050 FAX: +886-2-8511-3151**

**3F-4, No.8, Ln. 609, Sec. 5, Chongxin Rd., Sanchong Dist., New Taipei City 241, Taiwan (R.O.C.)**

## 9. Package Connections

### 9.1. 153 balls Package Mechanical (11.5 x 13.0 x 1.0mm)

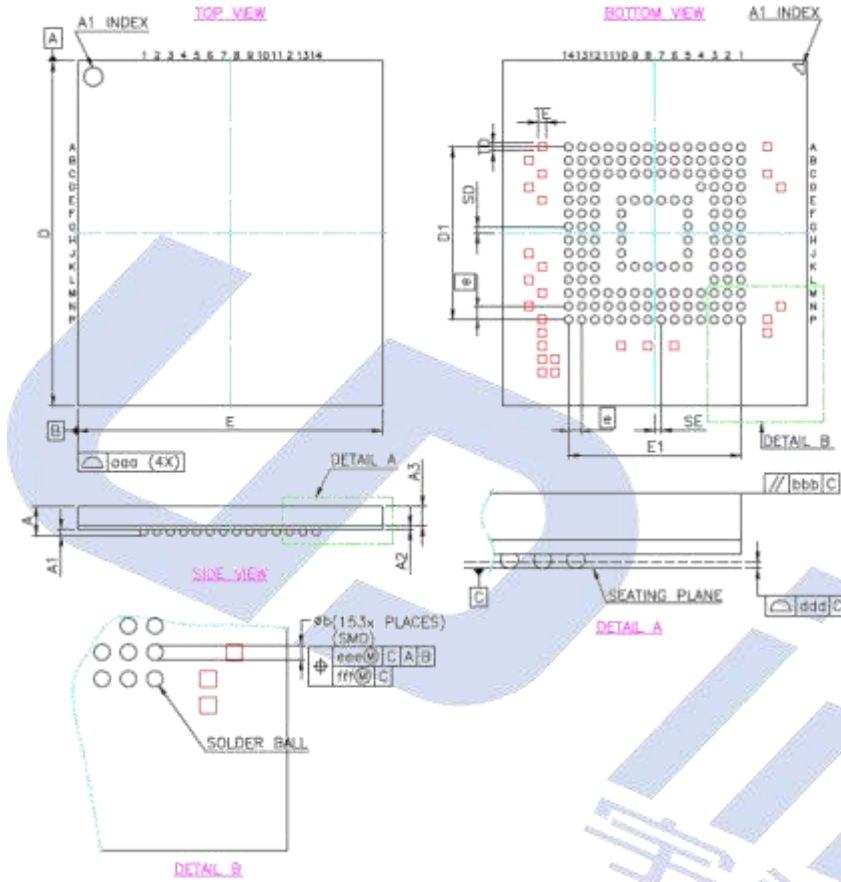

	SYM.	DIMENSION (mm)		
		MIN.	NOM.	MAX.
TOTAL THICKNESS	A	0.80	0.95	1.00
STAND OFF	A1	0.17	0.22	0.27
SUBSTRATE THICKNESS	A2	—	0.13	—
MOLD THICKNESS	A3	—	0.60	—
BALL WIDTH	b	0.25	0.30	0.35
BODY SIZE	D	12.90	13.00	13.10
BALL DIAMETER (PRE-REFLOW)		0.30		
BALL OPENING		0.275		
EDGE BALL CENTER TO CENTER	D1	6.50 BSC		
BODY SIZE	E	11.40	11.50	11.60
EDGE BALL CENTER TO CENTER	E1	6.50 BSC		
BODY CENTER TO CONTACT BALL	SD	0.25 BSC		
	SE	0.25 BSC		
JEDEC(REF)		MO-276(REF.)		
BALL PITCH	(P)	0.50 BSC		
BALL COUNT	N	153		
TEST PAD	TE	0.25	0.30	0.35
TEST PAD	TB	0.25	0.30	0.35
PACKAGE EDGE TOLERANCE	aaa	0.15		
MOLD FLATNESS	bbb	0.20		
COPLANARITY	ddd	0.08		
BALL OFFSET(PACKAGE)	eee	0.15		
BALL OFFSET(BALL)	fff	0.05		

NOTE:  
1. CONTROLLING DIMENSION : MILLIMETER.

UD info CORP. TEL: +886-2-7713-6050 FAX: +886-2-8511-3151

3F-4, No.8, Ln. 609, Sec. 5, Chongxin Rd., Sanchong Dist., New Taipei City 241, Taiwan (R.O.C.)

## 10. Signal Assignment



### 10.1. 153 balls

	1	2	3	4	5	6	7	8	9	10	11	12	13	14	
A	NC	NC	DAT0	DAT1	DAT2	VSS	RFU	NC	NC	NC	NC	NC	NC	NC	A
B	NC	DAT3	DAT4	DAT5	DAT6	DAT7	NC	NC	NC	NC	NC	NC	NC	NC	B
C	NC	VDDI	NC	VSSQ	NC	VCCQ	NC	NC	NC	NC	NC	NC	NC	NC	C
D	NC	NC	NC	NC								NC	NC	NC	D
E	NC	NC	NC		RFU	VCC	VSS	VSF	VSF	VSF		NC	NC	NC	E
F	NC	NC	NC		VCC					VSF		NC	NC	NC	F
G	NC	NC	RFU		VSS					VSF		NC	NC	NC	G
H	NC	NC	NC		DS					VSS		NC	NC	NC	H
J	NC	NC	NC		VSS					VCC		NC	NC	NC	J
K	NC	NC	NC		RST_n	RFU	RFU	VSS	VCC	VSF		NC	NC	NC	K
L	NC	NC	NC									NC	NC	NC	L
M	NC	NC	NC	VCCQ	CMD	CLK	NC	NC	NC	NC	NC	NC	NC	NC	M
N	NC	VSSQ	NC	VCCQ	VSSQ	NC	NC	NC	NC	NC	NC	NC	NC	NC	N
P	NC	NC	VCCQ	VSSQ	VCCQ	VSSQ	RFU	NC	NC	VSF	NC	NC	NC	NC	P

153 balls assignment

UD info CORP. TEL: +886-2-7713-6050 FAX: +886-2-8511-3151

3F-4, No.8, Ln. 609, Sec. 5, Chongxin Rd., Sanchong Dist., New Taipei City 241, Taiwan (R.O.C.)

## 11. Signal Description



Pin	Description
CLK	Clock Signal.
CMD	Command Signal.
DS	Data Strobe Signal, Used in HS400 mode.
DAT0~7	Data Bus.
RST_N	Hardware Reset Signal.
VCC	Supply voltage for controller and Flash memory power.
VCCQ	Supply voltage for controller and Flash memory IO power.
VDDi	Connect capacitor from VDDi to GND for stabilize internal power.
VSS	Supply voltage ground for controller and Flash memory. Can be short with VSSQ.
VSSQ	Supply voltage ground for controller and IO Flash memory. Can be short with VSSQ.
NC	In eMMC chip is no connect. Left it floating.
RFU	Reserved for future use. Left it floating for future use.
VSF	Vendor Specific Function. Left it floating.

Some balls could be floated to achieve eMMC 4.5 force conversion.

- A6 VSS → Float NC
- J5 VSS → Float NC
- H5 DS → Float NC

**UD info CORP.** TEL: +886-2-7713-6050 FAX: +886-2-8511-3151

3F-4, No.8, Ln. 609, Sec. 5, Chongxin Rd., Sanchong Dist., New Taipei City 241, Taiwan (R.O.C.)



## 12. Part Number Decoder



EMC-F3UJX<sup>8</sup>X<sup>9</sup>X<sup>10</sup>X<sup>11</sup>X<sup>12</sup>X<sup>13</sup>X<sup>14</sup>X<sup>15</sup>X<sup>16</sup>X<sup>17</sup>

X <sup>1</sup> X <sup>2</sup> X <sup>3</sup>	X <sup>4</sup> X <sup>5</sup>	X <sup>6</sup> X <sup>7</sup>	X <sup>8</sup> X <sup>9</sup> X <sup>10</sup> X <sup>11</sup> X <sup>12</sup>	X <sup>13</sup>	X <sup>14</sup>	X <sup>15</sup>
EMC	F3	UJ	008GB 016GB 032GB 064GB 128GB	B: 3D TLC Industrial (-40°C~+85°C) C: 3D TLC Automotive Grade3 (-40°C~+85°C) D: 3D TLC Automotive Grade2 (-40°C~+105°C) R: 3D pSLC Industrial (-40°C~+85°C) S: 3D pSLC Automotive Grade3 (-40°C~+85°C) T: 3D pSLC Automotive Grade2 (-40°C~+105°C)	K: B16C	P

**UD info CORP. TEL: +886-2-7713-6050 FAX: +886-2-8511-3151**

3F-4, No.8, Ln. 609, Sec. 5, Chongxin Rd., Sanchong Dist., New Taipei City 241, Taiwan (R.O.C.)