

UD info Corp.

Industrial U.2 PCIe Solid State Drive

FIPS 140-3

PFD-25DB Series

Product DataSheet



© 2025 UD INFO Corp. All right reserved.

Specifications are subject to change without prior notice.

UD info CORP.

3F-4, No.8, Ln. 609, Sec. 5, Chongxin Rd., Sanchong Dist., New Taipei City 241, Taiwan (R.O.C.)

TEL: +886-2-7713-6050 FAX: +886-2-8511-3151

E-mail: sales@UDinfo.com.tw

1.	Introduction	5
1.1.	General Description	5
1.2.	Block Diagram	5
2.	Product Specifications.....	6
2.1.	Product Specifications.....	6
2.2.	Device Capacity	6
2.3.	Performance	7
2.4.	Thermal Throttling.....	8
2.5.	TCG Opal 2.0.....	10
3.	Environmental Specifications	11
3.1.	Environmental Conditions	11
3.1.1.	Temperature Specification	11
3.1.2.	Mechanical Specification	11
3.1.3.	Electrostatic Discharge (ESD)	11
3.1.4.	EMI Compliance	12
3.2.	TBW (TeraBytes Written) and DWPD (Drive Write Per Day)	12
3.3.	UBER.....	13
3.4.	MTBF.....	13
4.	Electrical Specifications	14
4.1.	Supply Voltage.....	14
4.2.	Power Consumption.....	14
5.	Interface.....	15
5.1.	Pin Assignment and Descriptions	15
6.	Supported Commands.....	18
6.1.	NVMe Command List.....	18
6.2.	Identify Device Command.....	20
6.3.	SMART Attributes.....	26
7.	Physical Dimension	27
7.1.	U.2 15mm Mechanical Diagram.....	27
8.	Ordering Information.....	28

Revision History

Revision	Draft Date	History	Author
Preliminary	2025/9/24	Preliminary version	Golden Lee



Product Overview

- **Capacity**
 - 1TB up to 8TB
 - * 8TB only support in C-temp
- **Form Factor**
 - U.2
- **PCIe Interface**
 - PCIe Gen4 x4
 - NVMe 1.4
 - PCI Express Base 4.0
- **Performance¹**
 - Sequential Read up to 7,000 MB/s
 - Sequential Write up to 2,000 MB/s
 - Random 4k Read up to 850K IOPS
 - Random 4K Write up to 500K IOPS
- **Temperature Range²**
 - Operation Temperature:
 - Standard: 0°C ~ 70°C
 - Wide: -40°C ~ 85°C
 - Storage Temperature:
 - -40°C ~ 85°C
- **Power Consumption³**
 - Active mode (Max.): < 12W
 - Idle mode: < 3.1W
- **ECC**
 - LDPC / RAID ECC
 - Low density parity check code (>120bit/KBytes)
- **Reliability**
 - MTBF: 2 million hours
 - UBER: < 1 sector per 10¹⁶ bits
 - TBW: TBC
 - DWPD ≥ TBC
- **Environment Specification**
 - Shock: 1500G_{0-P}/0.5ms duration
 - Vibration: 20Hz~80Hz/1.52mm
80Hz~2000Hz/20G_{P-P}
 - Drop: 80cm height/each face
 - Conflicting Material: Concrete floor
- **RoHS Compliant**
- **EMI Compliant**
 - CE: EN55032, CISPR 32
 - FCC: ANSI C63.4
 - BSMI: CNS 15936
 - VCCI: CISPR 32
- **Features Support List**
 - TCG Pyrite/OPAL
 - FIPS 140-3 lv2 **on going:**
Certificate number #

Notes:

1. Refer to Chapter 2.3 for more details.
2. The operation temperature means the case temperature, in which can be detected via the S.M.A.R.T.
Operation temperature range depends on NAND flash applied capability, which maximum value is listed.
3. Refer to Chapter 4, section 4.2 power consumption for more details.

1. INTRODUCTION

1.1. General Description

This document describes the specifications of UDinfo U.2 PCIe Solid State Drive. UDinfo U.2 delivers all the advantages of flash disk technology with PCIe Gen4 x4 interface. It offers a wide range capacity up to 8TB and its w/o SLC (default setting) performance can reach up to 7,000 MB/s (for read) and 2,000 MB/s (for write) based on 112Layer 3D TLC NAND flash with the choice of 1GB/2GB/4GB DDR4.

1.2. Block Diagram

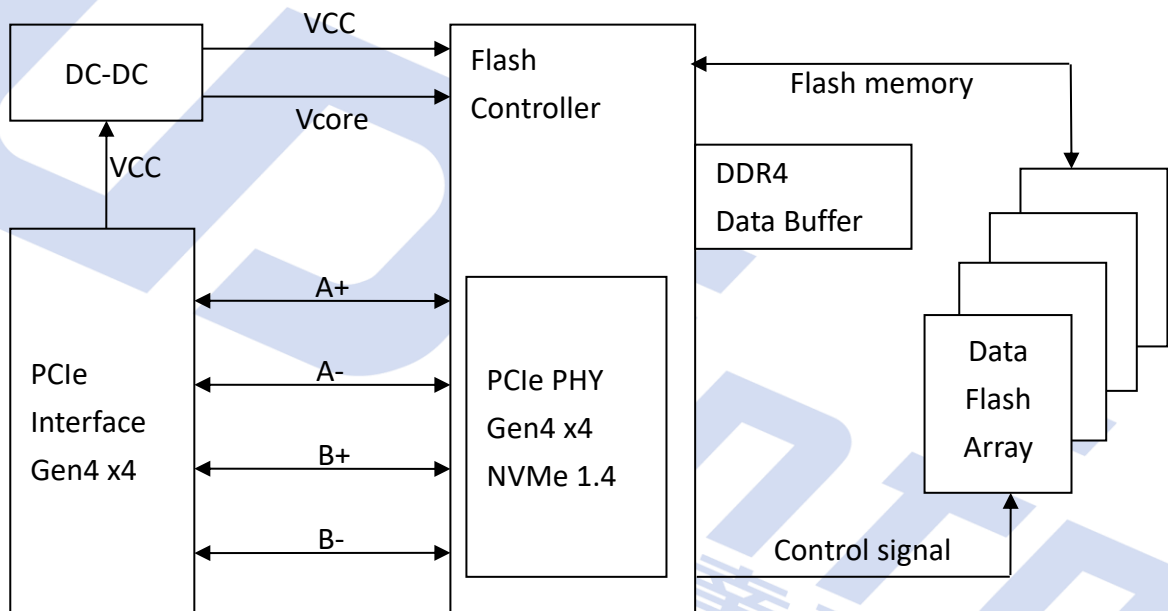

U.2 PCIe SSD Block Diagram

2. PRODUCT SPECIFICATIONS



2.1. Product Specifications

- Capacity
 - 1TB up to 8TB⁴
- Electrical/Physical Interface
 - PCIe Interface
 - PCI Express Base Ver 4.0
 - Compliant with NVMe 1.4
 - PCIe Gen4 x 4 lane & backward compatible to PCIe Gen3, Gen2 and Gen1

2.2. Device Capacity

Capacity	IDEMA Standard		User Data Size
	512Bytes/Sector	4KBytes/Sector	
	Total Sectors (LBA)	Total Sectors (LBA)	
1TB	2,000,409,264	250,051,158	Depended on file management
2TB	4,000,797,360	500,099,670	
4TB	8,001,573,552	1,000,196,694	
8TB ⁴	16,003,125,936	2,000,390,742	

Notes:

1. 1 Gigabyte (GB) is equal to 1,000,000,000 Bytes; 1 sector is equal to 512 Bytes or 4K Bytes.
2. The calculation is following IDEMA Standard.
3. The total actual user data size of the SSD may be less than device capacity due to SSD format, SSD partition, operating system.
EX: OS shows 953.87GB (NTFS) on 1TB device.
4. 8TB only support in c-temp

2.3. Performance

Capacity	Flash Structure	Sequential (MB/s)		Random (IOPS)	
		Read	Write	Read	Write
1TB	Kioxia BiCS5, 512Gb 112Layers	6,800	700	270K	180K
2TB	Kioxia BiCS5, 512Gb 112Layers	7,000	1,400	500K	350K
4TB	Kioxia BiCS5, 512Gb 112Layers	4,800	2,000	500K	500K
8TB	Kioxia BiCS5, 1Tb 112Layers	6,600	1,800	850K	440K

Notes:

1. Adopts dynamic caching to deliver better performance and consumer user experience.
2. Performance may differ according to flash configuration, use condition, environment and platform.
3. Performance specification is under Thermal Throttling inactivated.
4. Tested with CrystalDiskMark 8.0, QD8T1, 1GB range for Sequential performance.
5. Tested with IOMeter, 1GB range, 4K data size, QD=128, 16 worker, 4k aligned for Random IOPS.
6. Operating System: Windows 10 Professional (x64); Intel Core i7-8700K CPU @ 3.70GHz
7. Measurement environment: Room temperature: 20~25°C, humidity: 40~60%RH, DC+12V condition.



2.4. Thermal Throttling

The purpose of thermal throttling is to prevent any components in a SSD from over-heating during read and write operations. The controller is designed with an on-die thermal sensor and with its accuracy, firmware can apply different levels of throttling to achieve the purpose of protection efficiently and proactively via S.M.A.R.T. reading.

- **Purpose of Thermal Throttling:**
 - In order to keep the optimal performance in the safe range of the temperature.
- **Thermal sensors:**
 - We have external thermal sensor & on-die thermal sensor (internal controller) to detect temperature. There is 1pcs external thermal sensor on PCB, the position depends on different form factor (The thermal sensor is shown below. The picture is for reference only).
 - External thermal sensor would detect flash temperature; On-die thermal sensor detect controller temperature.

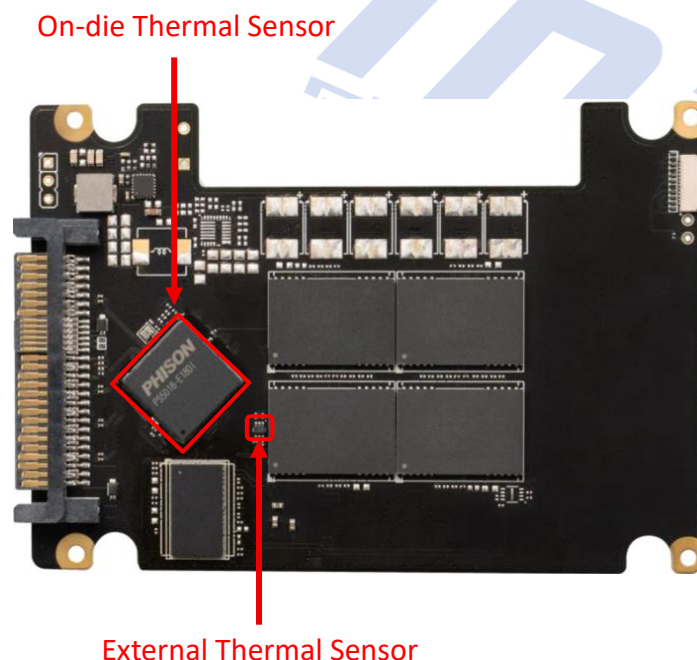

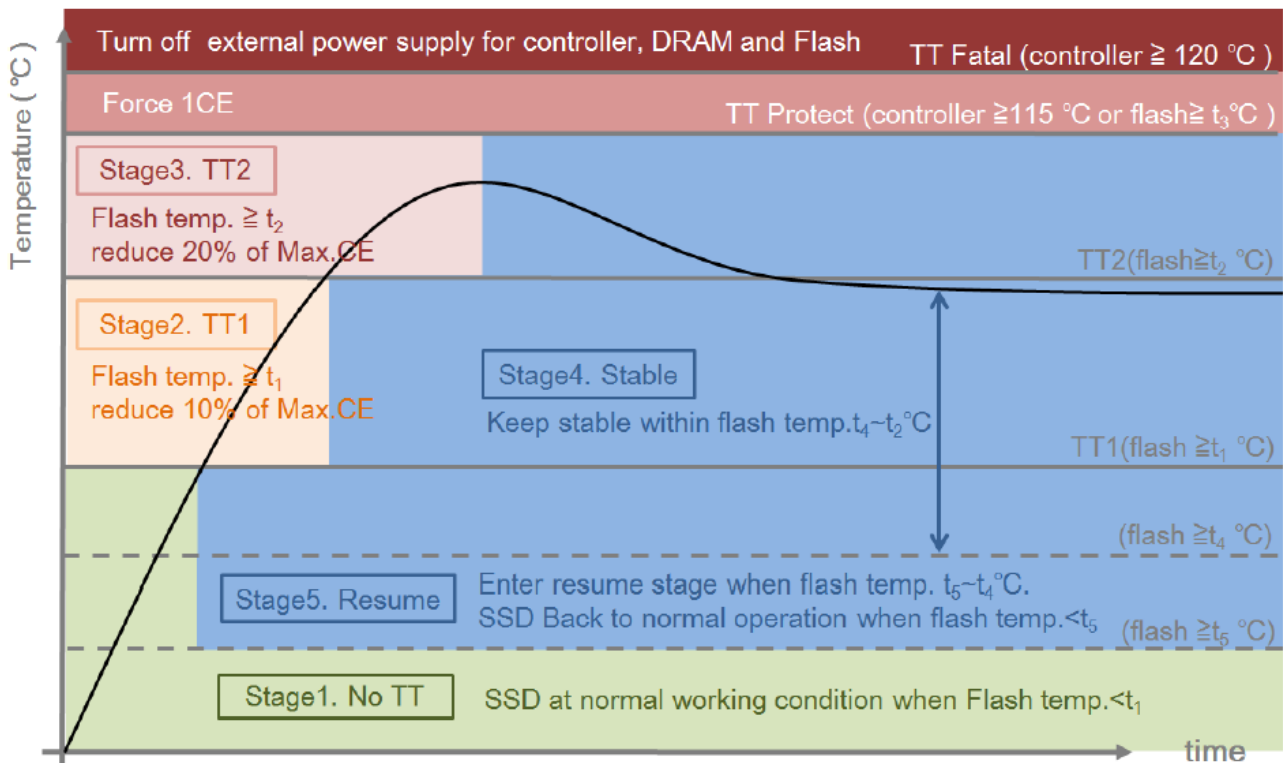

Figure 2-1 Thermal Throttling Schematic

	Operation temp. of Normal-temp. grade: 0°C ~ 70°C	Operation temp. of Wide-temp. grade: -40°C ~ 85°C
t₁	76°C	82°C
t₂	78°C	85°C
t₃	88°C	95°C
t₄	72°C	78°C
t₅	68°C	74°C

Notes:

1. TT shown on Figure 2-1 means "Thermal Throttling".
2. CE = Chip Enable.
3. temp. = temperature

2.5. TCG Opal 2.0

The Opal specification is a set of specifications for self-encrypting drives published by the Trusted Computing Group (TCG), a non-profit organization that develops, defines, and promotes standards and specifications for secure computing. The Opal Security Subsystem Class(SSC) 2.0 defines the details of data management in storage devices and the classes authority for data access, and secures data from theft and tampering by unauthorized persons who are able to gain access to the storage device or host system.

TCG Opal 2.0 Main Features:

- AES 256-bit Hardware Self Encryption
- Deploy Storage Device & Take Ownership:
The Storage Device is integrated into its target system and ownership transferred by setting or changing the Storage Device's owner credential.
- Activate or Enroll Storage Device:
LBA ranges are configured and data encryption and access control credentials (re)generated and/or set on the Storage Device. Access control is configured for LBA range unlocking.
- Lock & Unlock Storage Device:
Unlocking of one or more LBA ranges by the host and locking of those ranges under host control via either an explicit lock or implicit lock triggered by a reset event. MBR shadowing provides a mechanism to boot into a secure pre-boot authentication environment to handle device unlocking.
- Repurpose & End-of-Life:
Erasure of data within one or more.
- Physical Presence SID (PSID):
PSID is defined by TCG OPAL as a 32-character string and the purpose is to revert SSD back to its manufacturing setting when the drive is still OPAL-activated. PSID code can be printed on a SSD label when an OPAL-activated SSD supports PSID revert feature.

3. ENVIRONMENTAL SPECIFICATIONS



3.1. Environmental Conditions

3.1.1. Temperature Specification

	Mode	Min.	Max.	Unit
Temperature Ranges	Operation (Standard)	0	70	°C
	Operation (Wide)	-40	85	°C
	Storage	-40	85	°C
Humidity	Operation	5	95	%
	Storage	5	95	%
Temperature Cycle Test	Operation (Standard)	0	70	°C
	Operation (Wide)	-40	85	°C
	Storage	-40	85	°C

Notes:

- The operation temperature means the case temperature, in which can be detected via the S.M.A.R.T. Airflow is suggested and it will allow device to be operated at appropriate temperature for each component during heavy workloads environment.

3.1.2. Mechanical Specification

Items			Condition
Shock	Non-operational	Acceleration Force	1500G 0-p with half sine wave (0.5ms)
Vibration	Non-operational	Frequency/Displacement	20Hz~80Hz/1.52mm
		Frequency/Acceleration	80Hz~2000Hz/20G p-p with sine wave
Drop	Non-operational	Height of Drop	80cm free fall
		Number of Drop	6 face of each unit
		Conflicting Material	Concrete floor

3.1.3. Electrostatic Discharge (ESD)

Specification	+/- 4KV
EN 55035, CISPR 35 EN 61000-4-2 and IEC 61000-4-2	Device functions are affected, but EUT will be back to its normal or operational state automatically.

3.1.4. EMI Compliance

Specification
CE: EN 55032, CISPR 32
FCC: ANSI C63.4
VCCI: CISPR 32
BSMI: CNS 15936

3.2. TBW (TeraBytes Written) and DDPD (Drive Write Per Day)

Capacity	Flash Type	TBW	DDPD
1TB	Kioxia BiCS5, 512Gb 112Layers	TBC	TBC
2TB	Kioxia BiCS5, 512Gb 112Layers	TBC	TBC
4TB	Kioxia BiCS5, 512Gb 112Layers	TBC	TBC
8TB	Kioxia BiCS5, 1Tb 112Layers	TBC	TBC

Notes:

1. TBW is measured by JEDEC Client 219A workload and calculated with PE count = 3000.
2. TBW may differ according to flash configuration and platform.
3. DDPD is calculated based on 3-year lifetime.
4. $DDPD = TBW / (365 \times 3 \text{ years} \times \text{User capacity})$
5. The SSD supports trim function. If Operation System does not support trim command, performance and TBW will be affected. (Like certain Windows OS, Linux kernel version before 2.6.33, other OS please reference each own user manual)
6. The endurance of SSD could be estimated based on user behavior, NAND endurance cycles, and write amplification factor.

3.3. UBER

Capacity	UBER
1TB ~ 8TB	< 1 sector per 10 ¹⁶ bits read

Notes:

1. UBER (Uncorrectable Bit Error Rates) means the uncorrectable error per bits read.
2. UBER = FER (fail rate) / Data Size (user data bit).
3. FER = uncorrectable ECC frame number / total ECC frame number.
4. The LDPC for TLC ECC capability > 120bit/KB.

3.4. MTBF

MTBF, Mean Time between Failures, is a measure of reliability of a device. Its value represents the average time between a repair and the next failure. The unit of MTBF is in hours. The higher the MTBF value, the higher the reliability of the device.

Our MTBF result is based on simulation software (Relex 7.3). Please note that a lower MTBF should be expected for higher capacity drives, and we apply the lowest MTBF for all capacities.

Capacity	MTBF
1TB ~ 8TB	2 million hours

4. ELECTRICAL SPECIFICATIONS



4.1. Supply Voltage

Parameter	Rating
Operating Voltage	12V ± 5%
Rise Time (Max/Min)	100ms / 0.1ms
Fall Time (Max/Min)	1s / 10ms
Min. off Time ^{Note1}	1s

Notes:

1. Minimum time between power removed from SSD (Vcc < 100 mV) and power re-applied to the drive.
2. Ensure the voltage of each power domain in SSD has enough time to discharge less than 0.1V.
3. Rise Time during from 10% to 90% of 12V.
4. Fall Time during from 90% to 10% of 12V.

4.2. Power Consumption

Capacity	Flash Structure	Read	Write	Idle
1TB	Kioxia BiCS5, 512Gb 112Layers	9	8	3.1
2TB	Kioxia BiCS5, 512Gb 112Layers	10.5	9	3.1
4TB	Kioxia BiCS5, 512Gb 112Layers	11.5	12	3.1
8TB	Kioxia BiCS5, 1Tb 112Layers	11.7	11.8	3.1

Unit: W

Notes:

1. Use CrystalDiskMark 7.0.0 with the setting of 1GB. Sequentially read and write the disk for 5 times, and measure power consumption during sequential Read [1/5]~[5/5] or sequential Write [1/5]~[5/5].
2. Power consumption may differ according to flash configuration, use condition, environment and platform.
3. The measured power voltage is 12V.
4. Measurement environment: Room temperature: 20~25°C, humidity: 40~60%RH, DC+12V condition.

5. INTERFACE



5.1. Pin Assignment and Descriptions

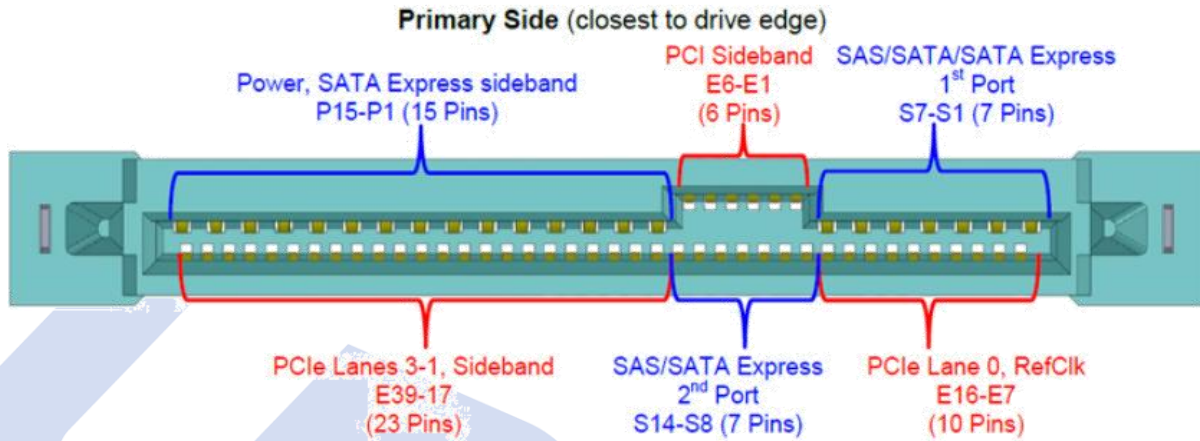

The follow table defines the signal assignment of the 2.5" PCIe SSD SFF-8639 Connector Pin Assignment and Descriptions.

Pin #	Name	Type	Description
P1	WAKE#	Bi-Dir	Signal for Link reactivation
P2	Reserved	Reserved	Reserved
P3	PWRDIS	Output	Power disable
P4	IfDet#	Input	Interface Type Detect
P5	Ground	Ground	Ground
P6	Ground	Ground	Ground
P7	+5V	Power	Reserved
P8	+5V	Power	Reserved
P9	+5V	Power	Reserved
P10	PRSNT#	Input	Presence detect
P11	Activity	Input	Activity indicator
P12	Ground	Ground	Ground
P13	+12V Precharge	Power	+12V Precharge power
P14	+12V	Power	+12V power
P15	+12V	Power	+12V power
SG1	Ground	Ground	Ground
SG2	Ground	Ground	Ground
S1	Ground	Ground	Ground

Pin #	Name	Type	Description
S2	Reserved	Reserved	Reserved
S3	Reserved	Reserved	Reserved
S4	Ground	Ground	Ground
S5	Reserved	Reserved	Reserved
S6	Reserved	Reserved	Reserved
S7	Ground	Ground	Ground
S8	Ground	Ground	Ground
S9	Reserved	Reserved	Reserved
S10	Reserved	Reserved	Reserved
S11	Ground	Ground	Ground
S12	Reserved	Reserved	Reserved
S13	Reserved	Reserved	Reserved
S14	Ground	Ground	Ground
S15	HPT0	Output	Host Port Type
S16	Ground	Ground	Ground
S17	TX p1	Diff-Pair	Transmitter differential pair, Lane 1
S18	TX n1	Diff-Pair	Transmitter differential pair, Lane 1
S19	Ground	Ground	Ground
S20	RX n1	Diff-Pair	Receiver differential pair, Lane 1
S21	RX p1	Diff-Pair	Receiver differential pair, Lane 1
S22	Ground	Ground	Ground
S23	TX p2	Diff-Pair	Transmitter differential pair, Lane 2
S24	TX n2	Diff-Pair	Transmitter differential pair, Lane 2
S25	Ground	Ground	Ground
S26	RX n2	Diff-Pair	Receiver differential pair, Lane 2
S27	RX p2	Diff-Pair	Receiver differential pair, Lane 2
S28	Ground	Ground	Ground
E1	REFCLKB+	Diff-Pair	Reference clock (differential pair) for second X2 port
E2	REFCLKB-	Diff-Pair	Reference clock (differential pair) for second X2 port
E3	+3.3 Vaux	Power	3.3 V auxiliary power
E4	CLKREQ#/PERSTB#	Bi-dir	Clock request / Fundamental reset for second X2 port
E5	PERST#	Output	Fundamental reset (if dual-port mode enabled, first X2 port)
E6	IFDet2#	Input	Interface Type Detect
E7	REFCLK+	Diff-Pair	Reference clock (if Dual Port mode enabled, first A-Side port)
E8	REFCLK-	Diff-Pair	Reference clock (if Dual Port mode enabled, first A-Side port)

Pin #	Name	Type	Description
E9	Ground	Ground	Ground
E10	TX p0	Diff-Pair	Transmitter differential pair, Lane 0
E11	TX n0	Diff-Pair	Transmitter differential pair, Lane 0
E12	Ground	Ground	Ground
E13	RX n0	Diff-Pair	Receiver differential pair, Lane 0
E14	RX p0	Diff-Pair	Receiver differential pair, Lane 0
E15	Ground	Ground	Ground
E16	HPT1	Output	Host Port Type
E17	TX p3	Diff-Pair	Transmitter differential pair, Lane 3
E18	TX n3	Diff-Pair	Transmitter differential pair, Lane 3
E19	Ground	Ground	Ground
E20	RX n3	Diff-Pair	Receiver differential pair, Lane 3
E21	RX p3	Diff-Pair	Receiver differential pair, Lane 3
E22	Ground	Ground	Ground
E23	SMCLK	Bi-Dir	SMBus (System Management Bus) clock
E24	SMDAT	Bi-Dir	SMBus (System Management Bus) data
E25	DualPortEn#	Output	Dual port Enable and Host Port Type control



6. SUPPORTED COMMANDS



6.1. NVMe Command List

Table 6-1 Admin Commands

Op-Code	O/M	Command Description
00h	M	Delete I/O Submission Queue
01h	M	Create I/O Submission Queue
02h	M	Get Log Page
04h	M	Delete I/O Completion Queue
05h	M	Create I/O Completion Queue
06h	M	Identify
08h	M	Abort
09h	M	Set Features
0Ah	M	Get Features
0Ch	M	Asynchronous Event Request
10h	O	Firmware Activate
11h	O	Firmware Image Download
14h	O	Device Self-test
80h	O	Format NVM
81h	O	Security Send
82h	O	Security Receive
84h	O	Sanitize

Table 6-2 I/O Commands

Op-Code	O/M	Command Description
00h	M	Flush
01h	M	Write
02h	M	Read
04h	O	Write Uncorrectable
05h	O	Compare
08h	O	Write Zeroes
09h	O	Dataset Management

Table 6-3 Set Feature Commands

Op-Code	O/M	Command Description
00h		Reserved
01h	M	Arbitration
02h	M	Power Management
03h	O	LBA Range Type
04h	M	Temperature Threshold
05h	M	Error Recovery
06h	O	Volatile Write Cache
07h	M	Number of Queues
08h	M	Interrupt Coalescing
09h	M	Interrupt Vector Configuration
0Ah	M	Write Atomicity Normal
0Bh	M	Asynchronous Event Configuration
0Ch	O	Autonomous Power State Transition
0Dh	O	Host Memory Buffer
0Eh	O	Timestamp
10h	O	Host Controlled Thermal Management
11h	O	Non-Operational Power State Config
0Eh – 7Dh	-	Reserved
80h	O	Software Progress Marker

Table 6-4 Get Log Page Commands

Op-Code	O/M	Command Description
00h	-	Reserved
01h	M	Error Information
02h	M	SMART / Health Information
03h	M	Firmware Slot Information
04h	O	Changed Namespace List
06h	O	Device Self-test
09h – 7Fh	-	Reserved
81h	O	Sanitize Status
82h - FFh	-	Reserved

6.2. Identify Device Command

The following table details the sector data returned by the IDENTIFY DEVICE command.

Table 6-5 Identify Controller Data Structure

Bytes	O/M	Description	Default Value
01:00	M	PCI Vendor ID (VID)	0x1987
03:02	M	PCI Subsystem Vendor ID (SSVID)	0x1987
23:04	M	Serial Number (SN)	TBD
63:24	M	Model Number (MN)	TBD
71:64	M	Firmware Revision (FR)	TBD
72	M	Recommended Arbitration Burst (RAB)	0x01
75:73	M	IEEE OUI Identifier (IEEE)	TBD*
76	O	Controller Multi-Path I/O and Namespace Sharing Capabilities (CMIC)	0x00
77	M	Maximum Data Transfer Size (MDTS)	0x09
79:78	M	Controller ID (CNTLID)	0x0001
83:80	M	Version (VER)	0x00010400
87:84	M	RTD3 Resume Latency (RTD3R)	0x00989680
91:88	M	RTD3 Entry Latency (RTD3E)	0x00989680
95:92	M	Optional Asynchronous Events Supported (OAES)	0x00000200
99:96	M	Controller Attributes (CTRATT)	0x0002
111:100	-	Reserved	0x0100000000000000 0000000000
127:112	O	FRU Globally Unique Identifier (FGUID[16])	0x00
239:128	-	Reserved	0x00
255:240	-	Refer to the NVMe Management Interface Specification for definition	0x00
257:256	M	Optional Admin Command Support (OACS)	0x0017
258	M	Abort Command Limit (ACL)	0x03
259	M	Asynchronous Event Request Limit (AERL)	0x03
260	M	Firmware Updates (FRMW)	0x12
261	M	Log Page Attributes (LPA)	0x0C
262	M	Error Log Page Entries (ELPE)	0x3E
263	M	Number of Power States Support (NPSS)	0x00
264	M	Admin Vendor Specific Command Configuration (AVSCC)	0x01

Bytes	O/M	Description	Default Value
265	O	Autonomous Power State Transition Attributes (APSTA)	0x00
267:266	M	Warning Composite Temperature Threshold (WCTEMP)	0x0165 (cTLC) 0x016B (gTLC)
269:268	M	Critical Composite Temperature Threshold (CCTEMP)	0x016A (cTLC) 0x0170 (gTLC)
271:270	O	Maximum Time for Firmware Activation (MTFA)	0x0064
275:272	O	Host Memory Buffer Preferred Size (HMPRE)	0x00000000
279:276	O	Host Memory Buffer Minimum Size (HMMIN)	0x00000000
295:280	O	Total NVM Capacity (TNVMCAP)	**
311:296	O	Unallocated NVM Capacity (UNVMCAP)	**
315:312	O	Replay Protected Memory Block Support (RPMBS)	0x00
317:316	O	Extended Device Self-test Time (EDSTT)	0x000A
318	O	Device Self-test Options (DSTO)	0x00
319	M	Firmware Update Granularity (FWUG)	0x01
321:320	M	Keep Alive Support (KAS)	0x0000
323:322	O	Host Controlled Thermal Management Attributes (HCTMA)	0x0001
325:324	O	Minimum Thermal Management Temperature (MNTMT)	0x0139
327:326	O	Maximum Thermal Management Temperature (MXTMT)	0x0160 (cTLC) 0x0166 (gTLC)
331:328	O	Sanitize Capabilities (SANICAP)	0x0A0000006
511:332	-	Reserved	0x00
NVM Command Set Attributes			
512	M	Submission Queue Entry Size (SQES)	0x66
513	M	Completion Queue Entry Size (CQES)	0x44
515:514	M	Maximum Outstanding Commands (MAXCMD)	0x0200
519:516	M	Number of Namespaces (NN)	0x00000001
521:520	M	Optional NVM Command Support (ONCS)	0x005D
523:522	M	Fused Operation Support (FUSES)	0x0000
524	M	Format NVM Attributes (FNA)	0x00
525	M	Volatile Write Cache (VWC)	0x07
527:526	M	Atomic Write Unit Normal (AWUN)	TBD
529:528	M	Atomic Write Unit Power Fail (AWUPF)	TBD
530	M	NVM Vendor Specific Command Configuration (NVSCC)	0x01
531	M	Namespace Write Protection Capabilities (NWPC)	0x00
533:532	O	Atomic Compare & Write Unit (ACWU)	0x0000
535:534	-	Reserved	0x0000

UD info CORP. TEL: +886-2-7713-6050 FAX: +886-2-8511-3151

3F-4, No.8, Ln. 609, Sec. 5, Chongxin Rd., Sanchong Dist., New Taipei City 241, Taiwan (R.O.C.)

Bytes	O/M	Description	Default Value
539:536	O	SGL Support (SGLS)	0x00000000
767:540	-	Reserved	0x00
IO Command Set Attributes			
1023:768	M	NVM Subsystem NVMe Qualified Name (SUBNQN)	0x00
1791:1024	-	Reserved	0x00
2047:1792	-	Reserved	0x00
2079:2048	M	Power State 0 Descriptor (PSD0)	TBD
2111:2080	O	Power State 1 Descriptor (PSD1)	0x00
2143:2112	O	Power State 2 Descriptor (PSD2)	0x00
2175:2144	O	Power State 3 Descriptor (PSD3)	0x00
2207:2176	O	Power State 4 Descriptor (PSD4)	0x00
2239:2208	O	Power State 5 Descriptor (PSD5)	0x00
2271:2240	O	Power State 6 Descriptor (PSD6)	0x00
2303:2272	O	Power State 7 Descriptor (PSD7)	0x00
2335:2304	O	Power State 8 Descriptor (PSD8)	0x00
2367:2336	O	Power State 9 Descriptor (PSD9)	0x00
2399:2368	O	Power State 10 Descriptor (PSD10)	0x00
2431:2400	O	Power State 11 Descriptor (PSD11)	0x00
2463:2432	O	Power State 12 Descriptor (PSD12)	0x00
2495:2464	O	Power State 13 Descriptor (PSD13)	0x00
2527:2496	O	Power State 14 Descriptor (PSD14)	0x00
2559:2528	O	Power State 15 Descriptor (PSD15)	0x00
2591:2560	O	Power State 16 Descriptor (PSD16)	0x00
2623:2592	O	Power State 17 Descriptor (PSD17)	0x00
2655:2624	O	Power State 18 Descriptor (PSD18)	0x00
2687:2656	O	Power State 19 Descriptor (PSD19)	0x00
2719:2688	O	Power State 20 Descriptor (PSD20)	0x00
2751:2720	O	Power State 21 Descriptor (PSD21)	0x00
2783:2752	O	Power State 22 Descriptor (PSD22)	0x00
2815:2784	O	Power State 23 Descriptor (PSD23)	0x00
2847:2816	O	Power State 24 Descriptor (PSD24)	0x00
2879:2848	O	Power State 25 Descriptor (PSD25)	0x00
2911:2880	O	Power State26 Descriptor (PSD26)	0x00
2943:2912	O	Power State 27 Descriptor (PSD27)	0x00
2975:2944	O	Power State 28 Descriptor (PSD28)	0x00

Bytes	O/M	Description	Default Value
3007:2976	O	Power State 29 Descriptor (PSD29)	0x00
3039:3008	O	Power State 30 Descriptor (PSD30)	0x00
3071:3040	O	Power State 31 Descriptor (PSD31)	0x00
Vendor Specific			
4095:3072	O	Vendor Specific (VS)	Vendor Reserved

* The OUI shall be a valid IEEE/RAC assigned identifier that may be registered at <http://standards.ieee.org/develop/regauth/oui/public.html>.

** Depends on the using of capacity



Table 6-6 Identify Namespace Data Structure & NVM Command Set Specific

Bytes	O/M	Description	Default Value
7:0	M	Namespace Size (NSZE)	TBD*
15:8	M	Namespace Capacity (NCAP)	TBD*
23:16	M	Namespace Utilization (NUSE)	TBD*
24	M	Namespace Features (NSFEAT)	0x00
25	M	Number of LBA Formats (NLBAF)	0x01
26	M	Formatted LBA Size (FLBAS)	0x00
27	M	Metadata Capabilities (MC)	0x00
28	M	End-to-end Data Protection Capabilities (DPC)	0x00
29	M	End-to-end Data Protection Type Settings (DPS)	0x00
30	O	Namespace Multi-path I/O and Namespace Sharing Capabilities (NMIC)	0x00
31	O	Reservation Capabilities (RESCAP)	0x00
32	O	Format Progress Indicator (FPI)	0x00
33	O	Deallocate Logical Block Features (dlfeat)	0x09
35:34	O	Namespace Atomic Write Unit Normal (NAWUN)	0x0000
37:36	O	Namespace Atomic Write Unit Power Fail (NAWUPF)	0x0000
39:38	O	Namespace Atomic Compare & Write Unit (NACWU)	0x0000
41:40	O	Namespace Atomic Boundary Size Normal (NABSN)	0x0000
43:42	O	Namespace Atomic Boundary Offset (NABO)	0x0000
45:44	O	Namespace Atomic Boundary Size Power Fail (NABSPF)	0x0000
47:46	O	Namespace Optimal IO Boundary (NOIOB)	0x0000
63:48	O	NVM Capacity (NVMCAP)	TBD
103:64	O	Reserved	0x00
119:104	O	Namespace Globally Unique Identifier (NGUID)	0x00
127:120	O	IEEE Extended Unique Identifier (EUI64)	TBD*
131:128	M	LBA Format 0 Support (LBAF0)	0x02090000
135:132	O	LBA Format 1 Support (LBAF1)	0x010C0000
139:136	O	LBA Format 2 Support (LBAF2)	0x00000000
143:140	O	LBA Format 3 Support (LBAF3)	0x00000000
147:144	O	LBA Format 4 Support (LBAF4)	0x00000000
151:148	O	LBA Format 5 Support (LBAF5)	0x00000000
155:152	O	LBA Format 6 Support (LBAF6)	0x00000000
159:156	O	LBA Format 7 Support (LBAF7)	0x00000000
163:160	O	LBA Format 8 Support (LBAF8)	0x00000000

UD info CORP. TEL: +886-2-7713-6050 FAX: +886-2-8511-3151

3F-4, No.8, Ln. 609, Sec. 5, Chongxin Rd., Sanchong Dist., New Taipei City 241, Taiwan (R.O.C.)

Bytes	O/M	Description	Default Value
167:164	O	LBA Format 9 Support (LBAF9)	0x00000000
171:168	O	LBA Format 10 Support (LBAF10)	0x00000000
175:172	O	LBA Format 11 Support (LBAF11)	0x00000000
179:176	O	LBA Format 12 Support (LBAF12)	0x00000000
183:180	O	LBA Format 13 Support (LBAF13)	0x00000000
187:184	O	LBA Format 14 Support (LBAF14)	0x00000000
191:188	O	LBA Format 15 Support (LBAF15)	0x00000000
383:192	-	Reserved	0x00

* See IDEMA SPEC

** See IEEE EUI-64 SPEC

■ List of Identify Namespace Data Structure for Each Capacity

Capacity (GB)	Byte[7:0]: Namespace Size (NSZE)
1,024	773BD2B0h
2,048	EE7752B0h
4,096	1DCEE52B0h
8,192	3B9DC52B0h



6.3. SMART Attributes

■ SMART Attributes (Log Identifier 02h)

Bytes Index	Bytes	Description
[0]	1	Critical Warning
[2:1]	2	Composite Temperature
[3]	1	Available Spare
[4]	1	Available Spare Threshold
[5]	1	Percentage Used
[31:6]	26	Reserved
[47:32]	16	Data Units Read
[63:48]	16	Data Units Written
[79:64]	16	Host Read Commands
[95:80]	16	Host Write Commands
[111:96]	16	Controller Busy Time
[127:112]	16	Power Cycles
[143:128]	16	Power On Hours
[159:144]	16	Unsafe Shutdowns
[175:160]	16	Media and Data Integrity Errors
[191:176]	16	Number of Error Information Log Entries
[195:192]	4	Warning Composite Temperature Time
[199:196]	4	Critical Composite Temperature Time
[201:200]	2	Temperature Sensor 1 (CTRL Tj)
[203:202]	2	Temperature Sensor 2 (N/A)
[205:204]	2	Temperature Sensor 3 (N/A)
[207:206]	2	Temperature Sensor 4 (N/A)
[209:208]	2	Temperature Sensor 5 (N/A)
[211:210]	2	Temperature Sensor 6 (N/A)
[213:212]	2	Temperature Sensor 7 (N/A)
[215:214]	2	Temperature Sensor 8 (N/A)
[511:216]	296	Reserved

7. PHYSICAL DIMENSION



7.1. U.2 15mm Mechanical Diagram

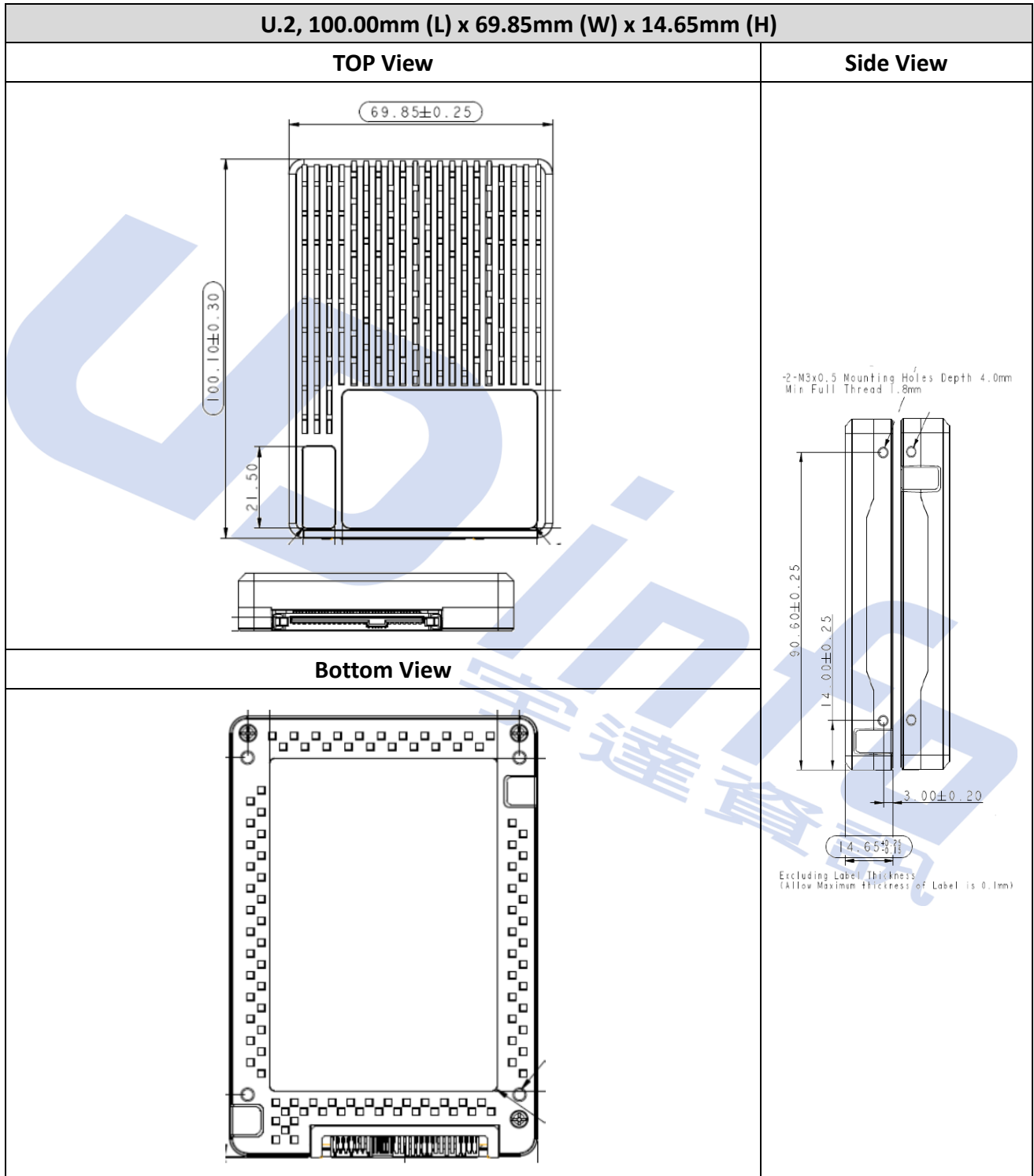

8. ORDERING INFORMATION



Capacity	Part Number
1TB	PFD-25DB001TB-BFP
2TB	PFD-25DB002TB-BFP
4TB	PFD-25DB004TB-BFP
8TB	PFD-25DB008TB-AFP

